

WINGET

OPERATING INSTRUCTIONS & SPARE PARTS LIST

4S DIESEL DUMPER (CAPACITY 30 CWT)

**FIRST ISSUED OCTOBER 1971
REVISED JULY 1972, FEBRUARY
1975, JULY 1977 & MAY 1981
REPRINTED JULY 2002**

**WINGET LIMITED
PO BOX 41
EDGEFOLD INDUSTRIAL ESTATE
PLODDER LANE
BOLTON
LANCS
BL4 OLS
TEL: ++ 44 (0) 1204 854650
FAX: ++ 44 (0) 1204 854663
service@winget.co.uk
parts@winget.co.uk
winget.co.uk**

INTRODUCTION

This Parts & Operators Manual is a re-print of the manual last published in 1981 and contains some amended part numbers.

Health & Safety legislation and working practices applicable to Site Dumpers, both 2 and 4 wheel Drive, Rigid Chassis and Articulated Chassis have changed considerably in the years since this manual was last published and immediately following this Introduction are notes on the Safe Use of Site Dumpers. These notes supersede and replace all previous 'Dumper Safety' notes issued with Winget 4S Two Wheel Drive Dumpers

Reference is made on a number of pages to 'bolt c/w nut and washer', this no longer the case, fixings such as nuts, bolts, screws and washers should be ordered as individual items. A number of Whitworth and B.S.F fixings are now no longer available, in these cases the nearest metric equivalent size will be supplied.

The contents of this manual although correct at the time of publication, may be subject to alteration by the manufacturers without notice and Winget Limited can accept no responsibility for any errors or omissions contained within the following pages. Nor can we accept any liability whatsoever arising from the use of this manual howsoever caused.

Winget Limited operate a policy of continuous product development. Therefore, some illustrations or text within this publication may differ from your machine.

WINGET LIMITED
PO BOX 41
EDGEFOLD INDUSTRIAL ESTATE
PLODDER LANE
BOLTON
LANCS
BL4 OLS
TEL ++ 44 (0) 1204 854650
FAX ++ 44 (0) 1204 854663
E mail service@winget.co.uk
parts@winget.co.uk
www.winget.co.uk

Safety is the responsibility of all persons working with this machine. Think "safety" at all times. ***Read and remember the contents of this handbook.***

The safe working recommendations for specific tasks are found with the instructions for the relevant operation in this Handbook.

MACHINE MODIFICATION

WARNING Any modifications to the machine will affect its working parameters and safety factors. Refer to the Manufacturers before fitting any non-standard equipment or parts.



The Manufacturers accept no responsibility for any modifications made after the machine has left the factory, unless previously agreed by the Manufacturers in writing; the Manufacturers will accept no liability for damage to property, personnel or the machine if failure is brought about due to such modifications, or fitment of spurious parts.

TRAINING

WARNING Only trained operators should use this machine.



Operators should hold an appropriate full motor vehicle driving licence and undergo both a safety awareness course and a driver training course for Site dumpers run by the C.ITB or equivalent body leading to the award of a CTA.

It is strongly recommended that operators read the H.S.E. publication "Safe Working with Small Dumpers" which is available from government bookshops (HMSO) or from other bookshops quoting the following number ISBN O11 8836935. Another useful publication is British Standard number BS 6264, "Procedure for Operator Training For Earth Moving Machinery" available from the British Standard Institution.

RUNNING-IN

WARNING While a gradual 'running-in' of a new engine is not necessary, it is extremely important that the instructions given in *Section 2 "Operation"* on "Running-in a new engine" should be followed very closely during the first fifty hours of operation.



DRIVING

WARNING **NEVER** use the machine for purposes other than those for which it was designed. This machine was designed to carry loads such as soil, clay, sand, wet concrete, stone or other similar materials. It was not designed to carry loads which may move around in the skip uncontrollably, nor to carry any loads or materials which overhang the skip in any way. If in any doubt as to the suitability of this machine for a particular task, contact your nearest Distributor or the Manufacturer for advice.



ALWAYS be aware of local and national regulations governing the use of the machine.

NEVER commence work with the machine until the "Daily (or every ten hours)" service checks have been made. (*See Service Section* for details)

ALWAYS check wheel nut tightness daily.

NEVER carry passengers.

Ensure that the seat is securely fixed to the machine. Where seat belt restraints are fitted as part of Rops/Fops protection they must be worn. Check that the seat belt is in good condition, free from cuts and frayed edges.

ALWAYS remain in the driving seat whenever the engine is running. Never attempt to operate any controls unless seated.

ALWAYS apply the parking brake before leaving the driver's seat.

NEVER dismount with the engine running, and never leave the machine unattended with the key in the starter switch.

When Battery Isolators are fitted they must be activated only when the engine is turned off except in cases of emergency.

Activating a Battery Isolator when the engine is running can result in damage to the electrical components and circuits.

NEVER fill the fuel or hydraulic tanks with the engine running.

ALWAYS drive only on surfaces that are known to be stable.

ALWAYS keep the floor plates and walkways clean.

NEVER drive the machine close to the edge of any excavation. Always use effective wheel stops to prevent the machine running close to the edge. Make sure that the stops are in proportion to the size of the wheels and are set sufficiently far enough back from the edge of any excavation to prevent the weight of the load causing a collapse.

NEVER adjust the tyre pressures in an attempt to improve traction on soft ground or obtain a softer ride on hard ground. Incorrectly adjusted tyres can affect the steering and handling characteristics.

NEVER attempt to free a machine which is 'bogged down' by pushing with the bucket of a backhoe loader, tracked excavator or other similar machine.

NEVER make unnecessary "crash stops" when travelling at speed, especially in forward direction.

NEVER work under an unpropped skip. If the dumper was supplied with a special skip support always ensure that it is used.

SKIPS AND LOADING

WARNING NEVER exceed the rated payload. The weights of all loads above skip water level must be checked.



NEVER remain on the machine when loading the skip with excavators or loaders. Stop the engine, apply the parking brake, dismount, and stand well clear.

ALWAYS ensure that the load is evenly distributed in the skip.

NEVER carry loads or heap materials in such a manner as to affect the forward vision.

ALWAYS take extra care when tipping non free running loads.

NEVER use the skip in a tipped position to bulldoze heaped materials level or to backfill material into excavations.

TOWING

WARNING NEVER attempt to start the engine of a dumper by towing or pushing.



Dumpers are not designed as towing vehicles. However, trailers may be towed provided that:

- 1 The combined weight of the trailer and its load does not exceed the dumper "drawbar pull of 250kg (2500N)" and dumper "drawbar load of 50kg (500N)".
- 2 Trailers may be towed in first gear on level dry ground, provided a purpose made towing pin is used.
- 3 The dumper skip must be loaded with half the rated payload to ensure tyre adhesion when braking.

NEVER tow loads up, down or across gradients.

GRADIENTS

WARNING NEVER operate **Two Wheel Drive rigid chassis dumpers** on any gradients which exceed 10% (1 in 10), or across gradients which exceed 10% (1 in 10).



ALWAYS remember that slippery or loose surface conditions can adversely affect safe machine operation, including braking, particularly on gradients.

ALWAYS choose routes that avoid steep, slippery or loose gradients.

NEVER coast down gradients. Always negotiate gradients in first gear.

ALWAYS drive forwards up gradients when loaded.

ALWAYS reverse down gradients when loaded.

ALWAYS keep the load facing uphill.

NEVER park on a gradient. If this is unavoidable, *ALWAYS* chock the wheels.

NEVER attempt to turn on a gradient

NEVER tow up, down or across a gradient.

NEVER operate high discharge or rotating skips on gradients.

HYDRAULICS

WARNING *ALWAYS* "Dump" residual pressure from the system before leaving the machine or before carrying out any maintenance or adjustments.



If maintenance work requires the skip to be in the raised position, then it must be raised and supported before dumping the pressure.

Dump pressure by switching off the engine, then moving the hydraulic control lever several times in each direction.

NEVER leave the machine unattended with pressure in the system.

ALWAYS purge hydraulic rams before commencing work. With the engine running operate the hydraulic control to fully extend and retract the rams.

ALWAYS practise the greatest cleanliness in maintaining hydraulic components.

SERVICING

WARNING *ALWAYS* report any defect at once, before an accident or consequential damage can occur.



ALWAYS conform to service schedules except where:

- 1 Warning lights or warning indicators call for immediate attention.
- 2 Adverse conditions necessitate more frequent servicing.

ALWAYS wear correctly fitting protective clothing. Loose or baggy clothing can be extremely dangerous when working on running engines or machinery.

ALWAYS, where possible, work on or close to engines or machinery only when they are stopped. If this is not practical, remember to keep tools, test equipment and all parts of your body well away from the moving parts.

ALWAYS "Dump" pressure from the hydraulic system before carrying out any kind of maintenance or adjustment. (**see Service - Hydraulic system**).

ALWAYS avoid contact with exhaust pipes, exhaust manifolds and silencers when the engine is running; these can be very hot.

ALWAYS work out of doors, or in a well-ventilated area.

NEVER run an engine in an enclosed space. Exhaust fumes in enclosed areas can kill.

ALWAYS disconnect battery cables and remove battery before using an external charger, carrying out welding repairs or to prevent unauthorised usage when unattended or during a repair.

NEVER allow unqualified personnel to attempt to repair, remove or replace any part of the machine, or anyone to remove large or heavy components without adequate lifting tackle.

NEVER attempt to modify or repair Rops Frames or Fops Canopies by welding, drilling or any other means. Attempts to do so will invalidate Rops/Fops Certification.

ALWAYS obtain advice before mixing oils; some are incompatible. If in doubt drain and refill.

NEVER allow oils and fuels to come into regular contact with skin. This can lead to serious skin diseases including, medical evidence suggests, skin cancer. *ALWAYS* wear protective gloves when handling oils and fuels whether topping up, draining or refilling. *ALWAYS* wash hands if oils or fuels come into contact with the skin.

Many liquids used in this machine are harmful if taken internally or splashed into the eyes. In the event of accidentally swallowing oils, fuels, anti-freeze, battery acid etc, *DO NOT* encourage vomiting, seek qualified medical assistance immediately.

ALWAYS dispose of waste oils and fuels into waste oil storage tanks. If storage tanks are not available consult your distributor or local authority for addresses of local designated disposal points. It is illegal to dispose of waste oil into drains or water courses or to bury it.

Equipment which includes friction materials will sometimes contain asbestos. When removing friction material dust from components, such as when servicing brakes or clutches, do not blow out with an airline; it could be harmful to inhale the dust. Remove the dust with a vacuum cleaner or wipe clean with a damp rag. Waste should be placed in a sealed container, marked, and disposed of in accordance with local or national regulations.

The accumulated dust found in clutch housings may contain lead/antimony. No food should be eaten at a work place contaminated by this dust. Hands must be washed before eating. Do not blow out dust with an airline.

NEVER work under an unpropped skip. ***If the dumper was supplied with a special Skip Support always ensure that it is used.***

ALWAYS ensure that when using a starting handle that it is clean and in good condition. Keep the engine starting dog and the part of the starting handle that mates with it lightly lubricated (*Refer to the Engine Handbook*).

PREPARATION FOR USE

BEFORE THE DUMPER IS PUT INTO SERVICE ALWAYS CHECK THE FOLLOWING POINTS:—

- ENGINE:** Check the oil level on the dipstick (A), topping up if necessary to the full mark. See also recommended Lubricating Oils.
- GEARBOX:** Check the oil level on the dipstick (B), topping up if necessary to the full mark. See also Recommended Lubricating Oils.
- DRIVE AXLE:** Remove level plug (C) and check that oil is up to bottom of hole. Top up if necessary through filler plug (D). See also Recommended Lubricating Oils.
- STEERING BOX:** Remove oil level/filler plug (E) (accessible through bracket) and top up if necessary. See also Recommended Lubricating Oils.
- FUEL TANK:** Remove filler cap (F) and fill with diesel oil until approximately 1" from the top.
- NOTE:** Never allow fuel level to fall below 2" deep in the bottom of the tank.
- MISCELLANEOUS:** Check all wheel nuts for tightness.
Check all nuts and bolts for tightness. Loose nuts and bolts may lead to damage not covered by the Dumper Warranty.

HYDRAULIC BRAKE SYSTEM (if fitted)

Ensure the brake master cylinder reservoir is full of brake fluid. Top up if necessary to within $\frac{1}{4}$ " of the top of the reservoir. Use only brake fluid that conforms to SAE J.1703.

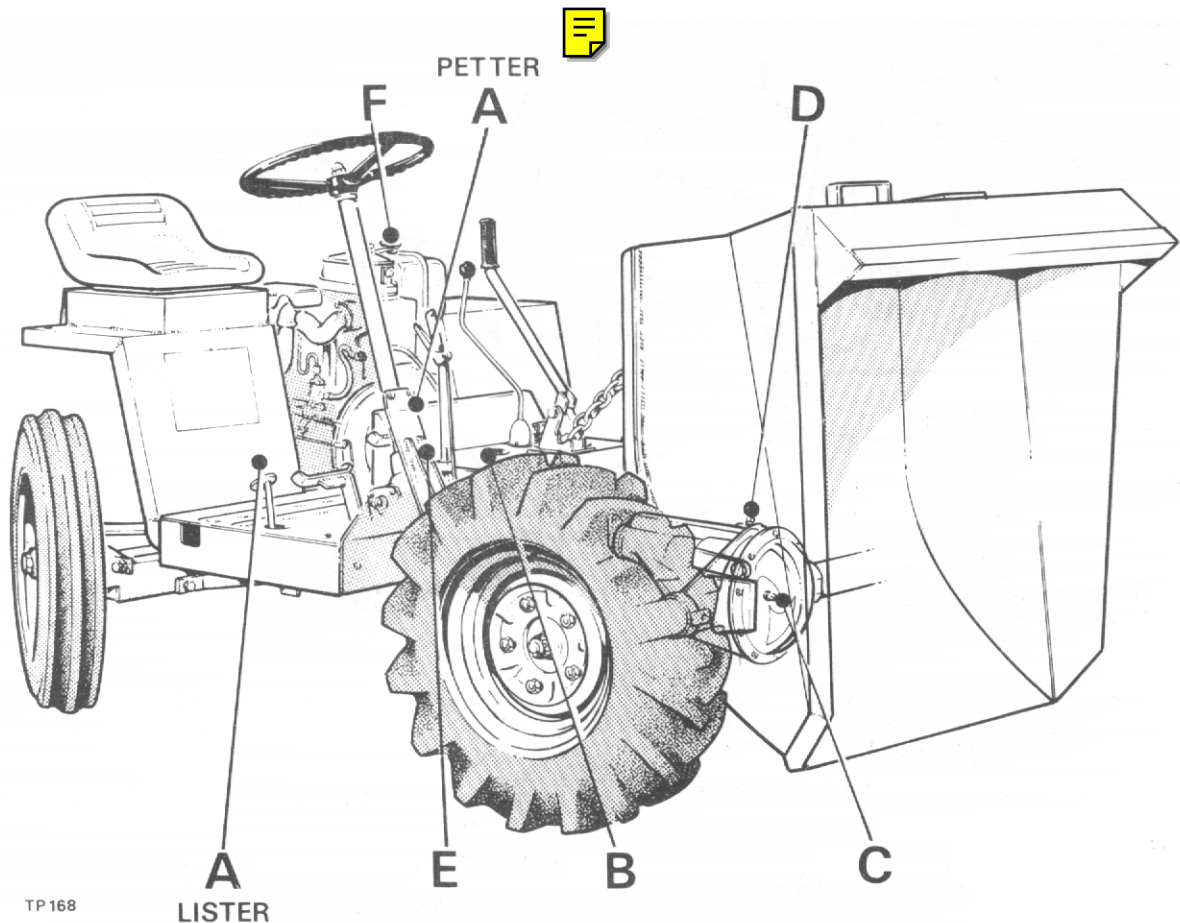

TP 168

LISTER

OPERATION (PETTER ENGINE)

Starting

1. Lift red-painted overload stop (A) situated on fuel pump immediately above priming level (B), and move fuel pump racks (C) into fully-open position.
2. Operate priming lever (B) six times.

NOTE: This is unnecessary if engine is already warm.

3. Lift decompression lever (E), positioned on top of engine and turn engine as fast as possible using starting handle. When engine is turning at a good speed knock down decompression lever and engine should fire.
4. If engine does not fire, lift decompression lever and slowly crank engine a few times before attempting to start again. Where ambient temperature is 5°F (-15°C) or below, a cold starting aid should be fitted.

Stopping

Hold the fuel pump rack (C) in the fully forward position, or lift the priming lever to the horizontal, until engine stops, then release.

Gear Shift Lever

The Dumper is fitted with three forward gears (1), (2), (3) and one reverse gear (R). When changing gear, the clutch pedal is used in the normal manner.

Skip Dump Lever

The skip dump lever (F) is located directly behind the skip. To deposit load, push lever forward. A manual operation returns the skip to its carrying position.

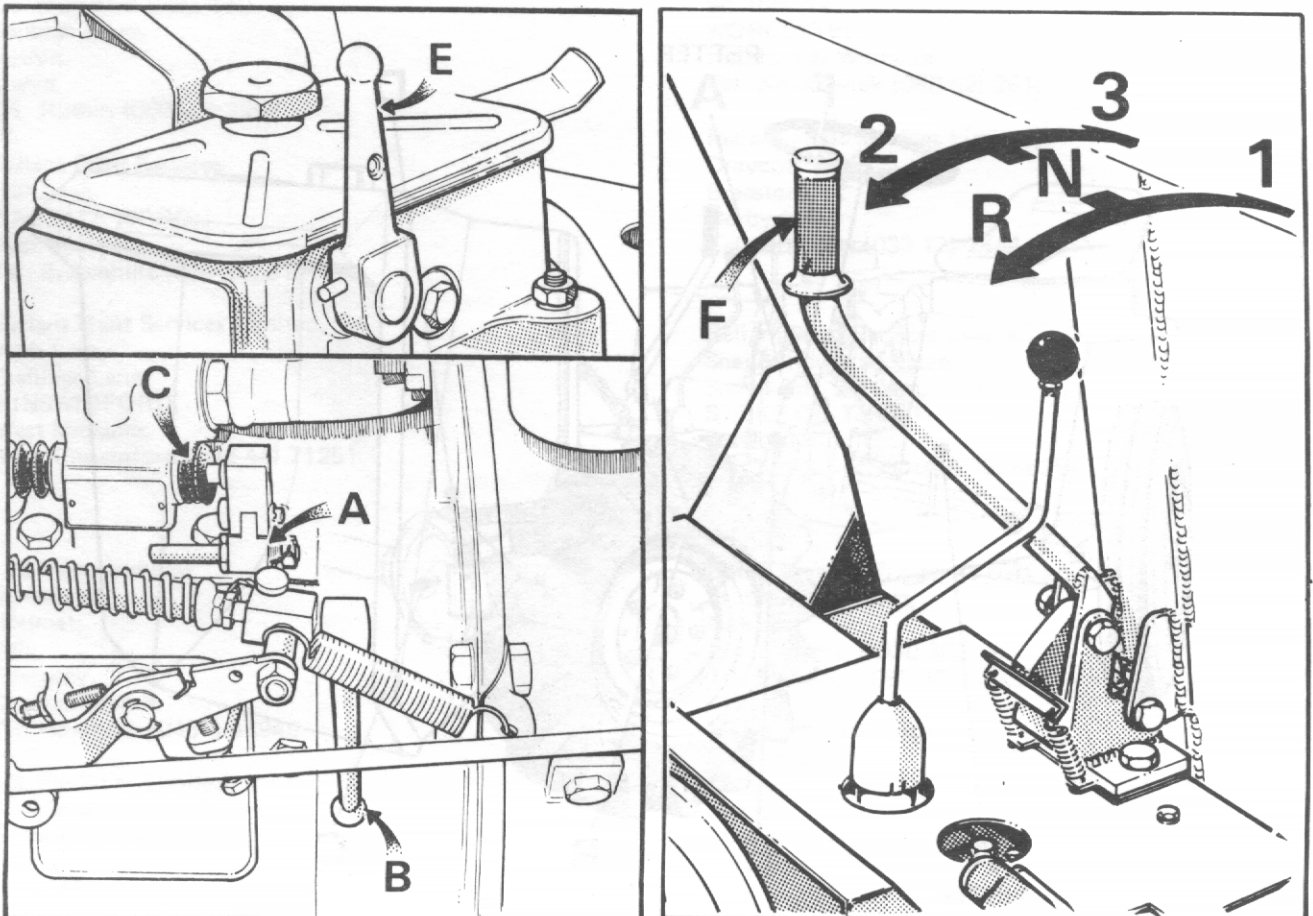

OPERATION (LISTER ENGINE)

Starting

1. Pull out overload lever (D) and lift to its highest position.

NOTE: This is unnecessary if engine is already warm.

2. Lift decompression levers (E), positioned on top of engine and turn engine as fast as possible using starting handle. When engine is turning at a good speed knock down decompression levers and engine should fire.
3. If engine does not fire, lift decompression lever and slowly crank engine a few times before attempting to start again. Where ambient temperature is 5°F (-15°C) or below, a cold starting aid should be fitted.
4. Set overload lever (D) horizontal when engine starts.

Stopping

Push overload lever (D) to its lowest position.

IMPORTANT:

1. DO NOT stop engine by means of decompression levers, this will lead to damaged valve seats and cylinder head joints.
2. DO NOT stop engine by closing fuel tap or by allowing fuel tank to run dry. This will allow air into fuel lines and necessitate bleeding and priming system.

NOTE: LISTER ENGINE has a self-bleeding fuel system.

Gear Shift Lever

The Dumper is fitted with three forward gears (1), (2), (3) and one reverse gear (R). When changing gear, the clutch pedal is used in the normal manner.

Skip Dump Lever

The skip dump lever (F) is located directly behind the skip. To deposit load, push lever forward. A manual operation returns the skip to its carrying position.

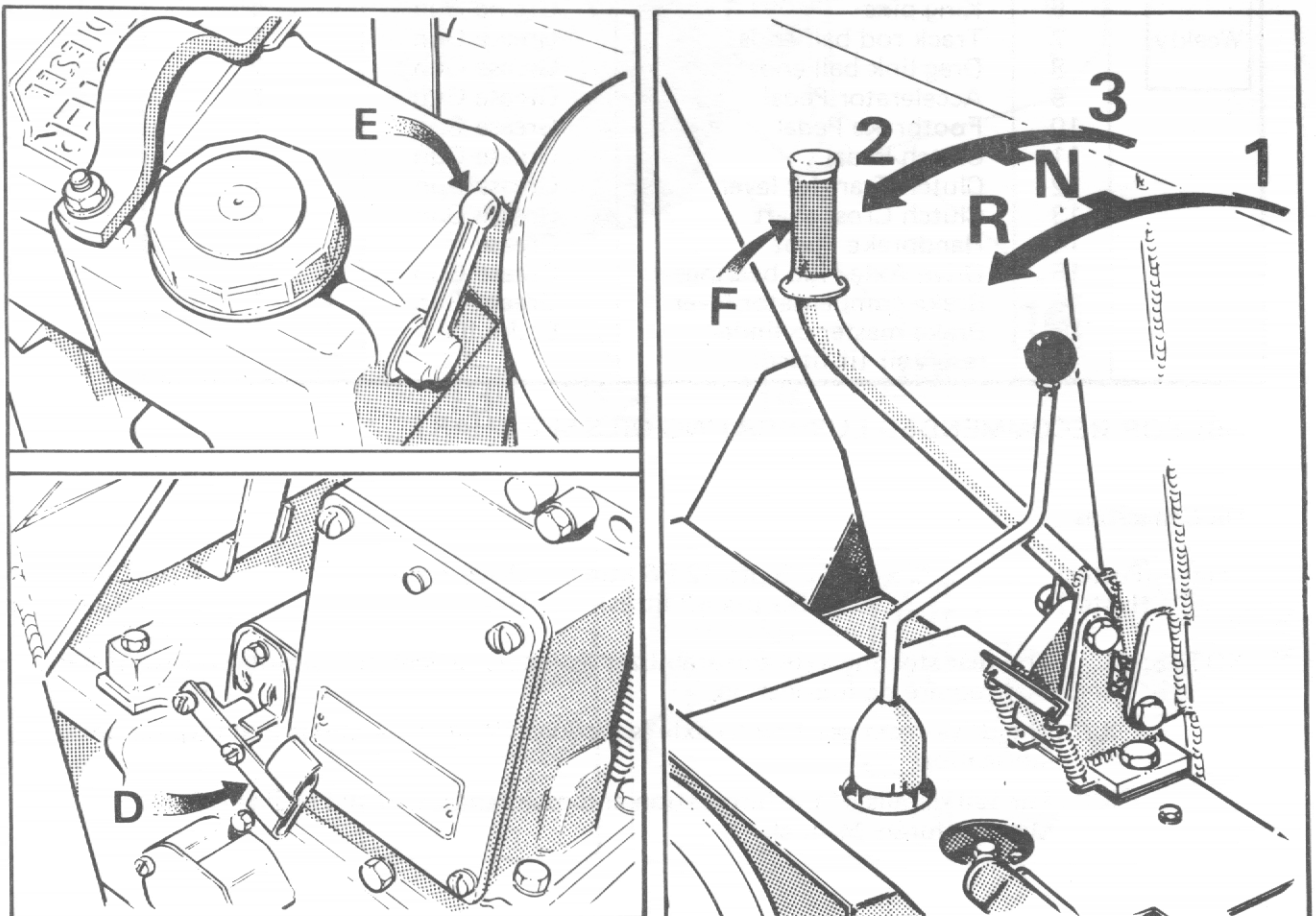

GENERAL MAINTENANCE

Periodic Maintenance

1. DAILY check engine oil level and fill to full mark on dipstick, if necessary.
2. DAILY fill fuel tank, Never allow there to be a depth of less than 2" of fuel in tank.
3. WEEKLY check oil level in gearbox and fill to full mark on dipstick, if necessary.
4. WEEKLY remove level plug from drive axle. Oil level should be to bottom of hole. Top up, if necessary.
5. WEEKLY remove level/filler plug from steering box and top up if necessary.
6. WEEKLY apply grease to all grease nipples.
7. WEEKLY check all wheel nuts and tighten, if necessary.
8. WEEKLY check tyre pressures (32 lbs./sq. in.)
9. OCCASIONALLY check all nuts and bolts and tighten, if necessary.

Lubrication

Period	Key to Fig.	Description	Lubrication	No. of points
Daily	1	Engine	Engine oil	1
	2	Fuel tank	Diesel Fuel	1
Weekly	3	Gearbox	Gearbox oil	1
	4	Drive Axle	Axle oil	1
	5	Steering box	Axle oil	1
	6	King pins	Grease Gun	4
	7	Track rod ball ends	Grease Gun	2
	8	Drag link ball ends	Grease Gun	2
	9	Accelerator Pedal	Grease Gun	1
	10	Footbrake Pedal	Grease Gun	1
	11	Clutch Pedal	Grease Gun	1
	12	Clutch Transfer lever	Grease Gun	1
	13	Clutch Cross shaft	Grease Gun	2
	14	Handbrake Pivot	Grease	1
	15	Drive Axle Hub bearings	Grease Gun	2
	16	Brake compensator lever	Grease Gun	1
	17	Brake master cylinder reservoir (if fitted)	Brake fluid	1

NB: FOR RECOMMENDED LUBRICATING OILS SEE CHART

Oil Capacities

Engine (Petter) 5 pts. (2.86 litres)	Drive Axle 8 pts. (4.57 litres)
(Lister) 3½ pts. (2 litres)	Gear box 2 pts. (.86 litres)

- NOTES: 1. The rear steering axle and stabilizer assembly articulation points consist of bearings that require no lubrication.
2. The drive from gearbox to axle is through flexible couplings that require no lubrication.
3. For full details of the lubrication and maintenance of the engine refer to Manufacturers Manual.

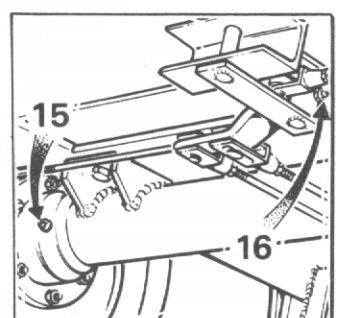
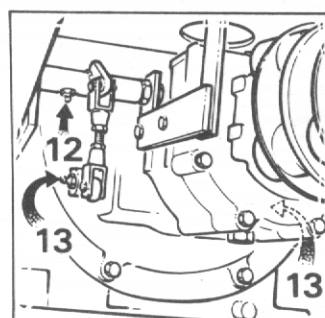
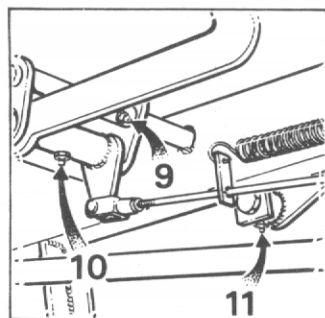
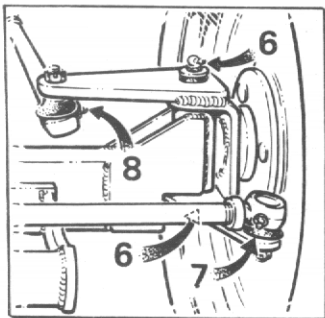
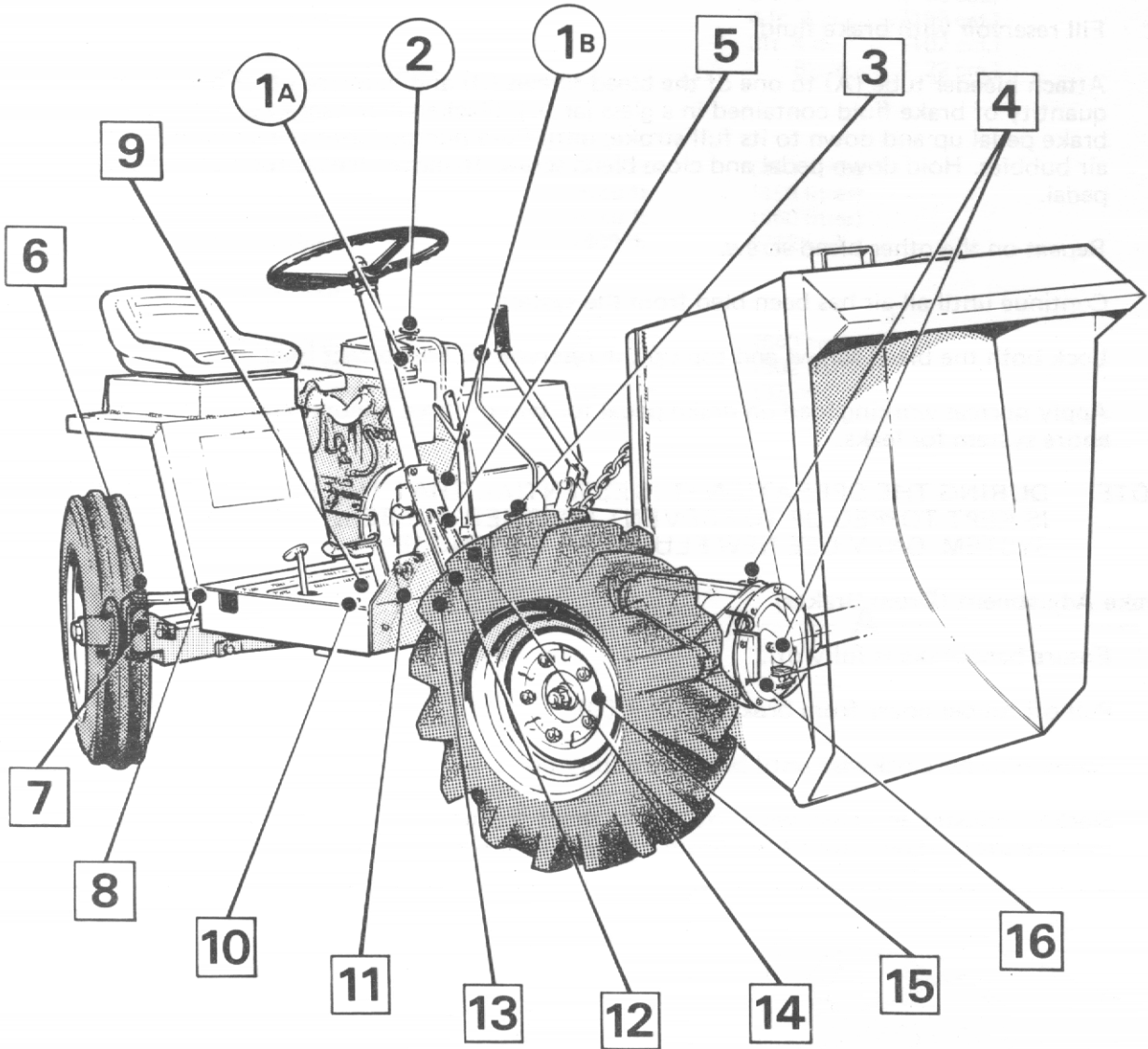
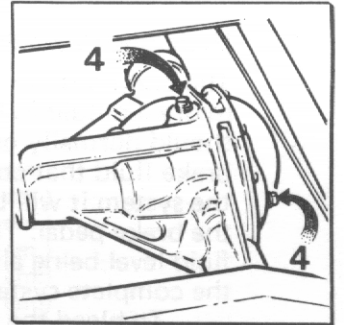
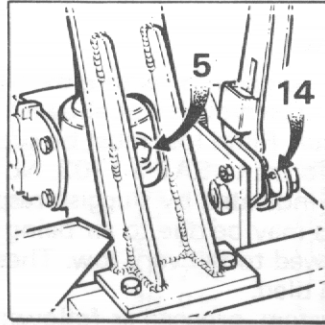
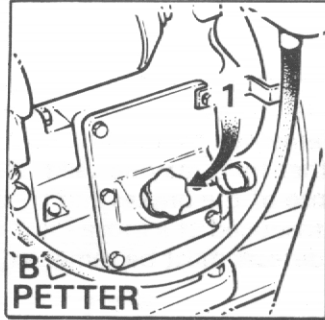
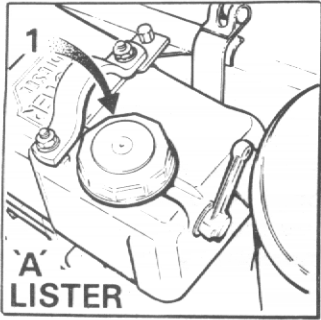

TP 170

LISTER FULL TANK CAPACITY
 20 PINTS (9.1 LITRES)
 PETER FULL TANK CAPACITY
 12 PINTS (5.8 LITRES)

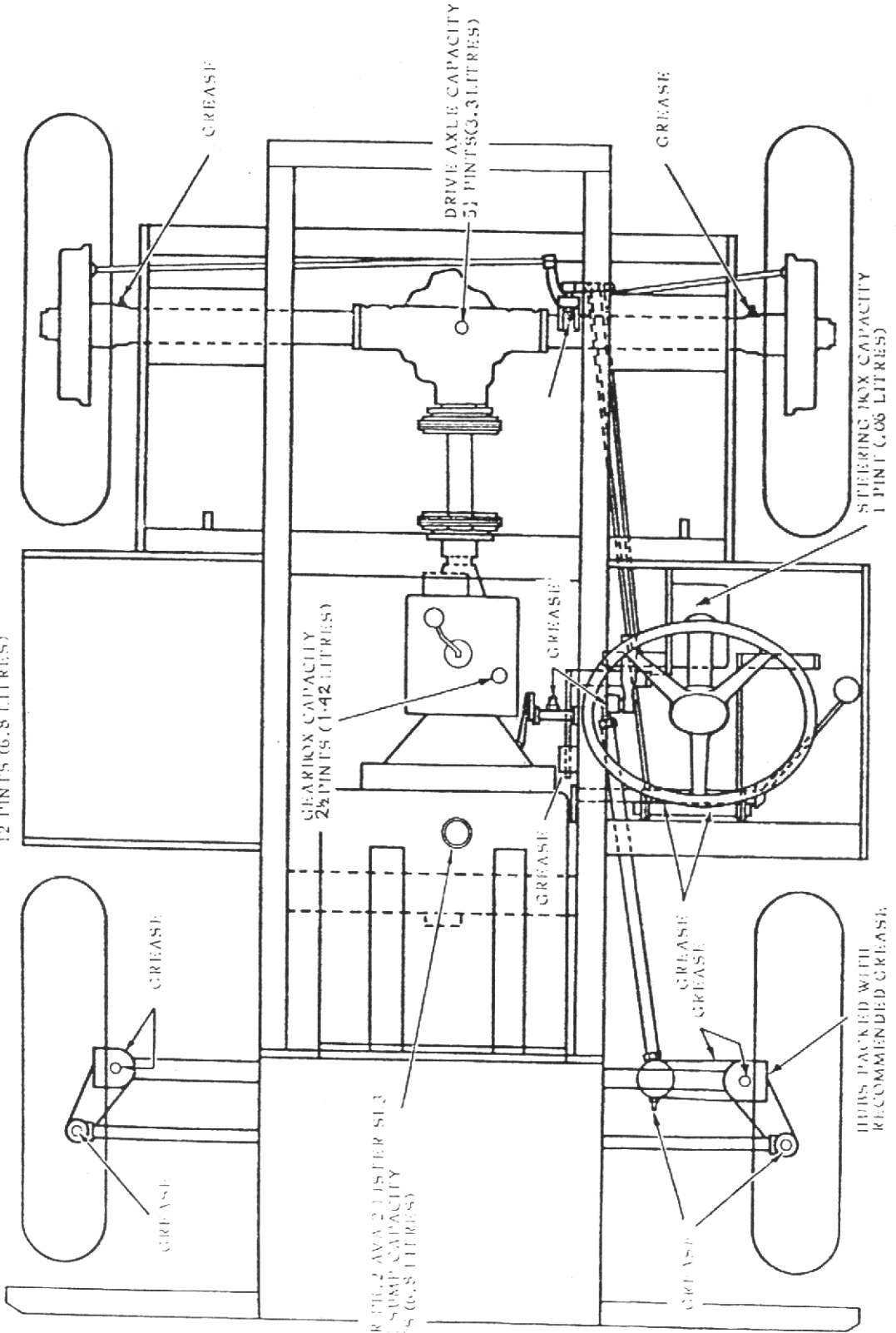

PETER FIG. 2 AWA 2 LISTER S13
 ENGINE SUMP CAPACITY
 12 PINTS (5.8 LITRES)

BUSHES PACKED WITH
 RECOMMENDED GREASE

Hydraulic Brake System

The brake system is designed to require the minimum of maintenance, and providing the hydraulic fluid in the reservoir is not allowed to fall below the recommended level, no defects should normally occur. Fluid loss must be supplemented by topping up the reservoir with brake fluid that conforms to SAE J 1703. No other fluid may be used. If air is present in the system it will be indicated by sluggish response of the brakes and by spongy action of the brake pedal. This may be due to air being introduced at a loose joint or by the reservoir fluid level being allowed to fall very low. These defects must be remedied immediately and the complete system bled.

To bleed the system, proceed as follows:—

1. Check that all connections are tight and all bleed screws are closed.
2. Fill reservoir with brake fluid.
3. Attach bleeder tube (A) to one of the bleed screws (B) and immerse other end in small quantity of brake fluid contained in a glass jar (C). Slacken bleed screw and operate brake pedal up and down to its full stroke, until fluid pumped into the jar contains no air bubbles. Hold down pedal and close bleed screw. Remove bleeder tube and release pedal.
4. Repeat on the other bleed screw.
5. Continue until all air has been bled from the system.
6. Lock both the bleed screws and top up the reservoir to the correct level.
7. Apply normal working load on brake pedal for two or three minutes and examine the entire system for leaks.

NOTE: DURING THE OPERATION IT IS ESSENTIAL THAT THE RESERVOIR LEVEL IS KEPT TOPPED UP TO PREVENT FURTHER AIR BEING DRAWN INTO THE SYSTEM. ONLY USE NEW FLUID FOR TOPPING UP.

Brake Adjustment (Drum Brakes)

1. Ensure handbrake is fully off.
2. Pull off rubber cover from brake adjuster (D).
3. Screw adjuster clockwise until brakes are fully on.
4. Slacken adjuster anti-clockwise until brake shoes are just clear of drum. This will cause shoes to be centralised on drums and ensure that whole brake lining area is used.

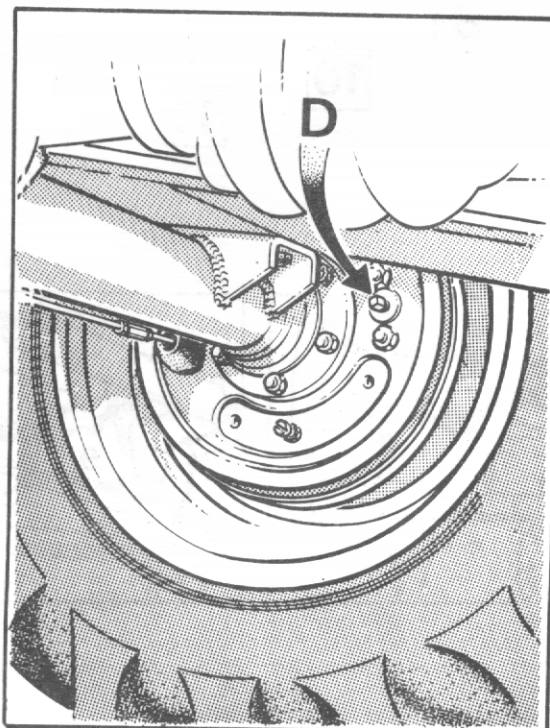
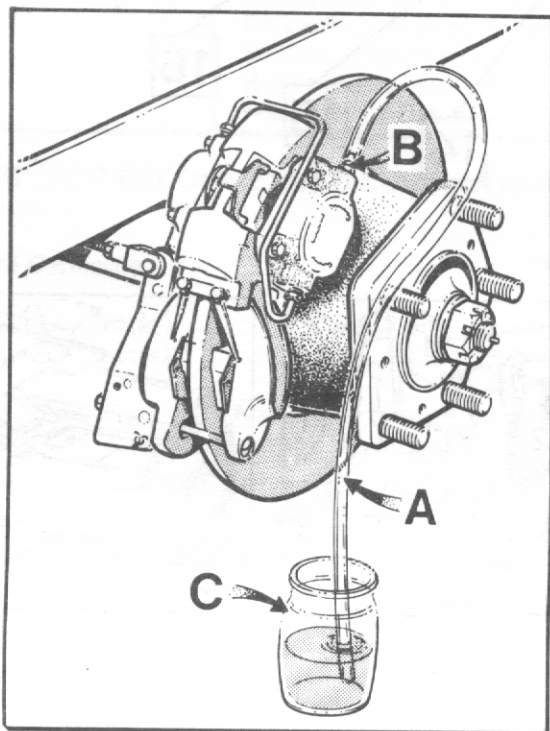

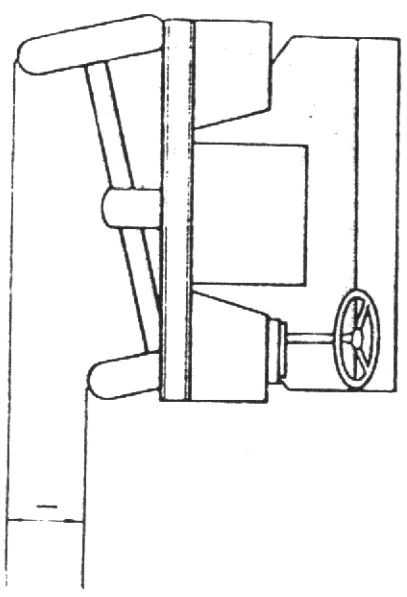
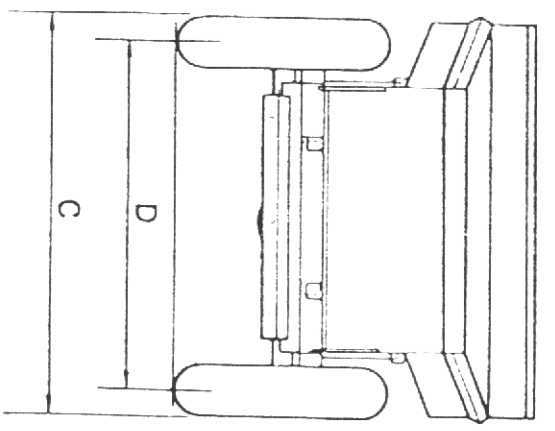
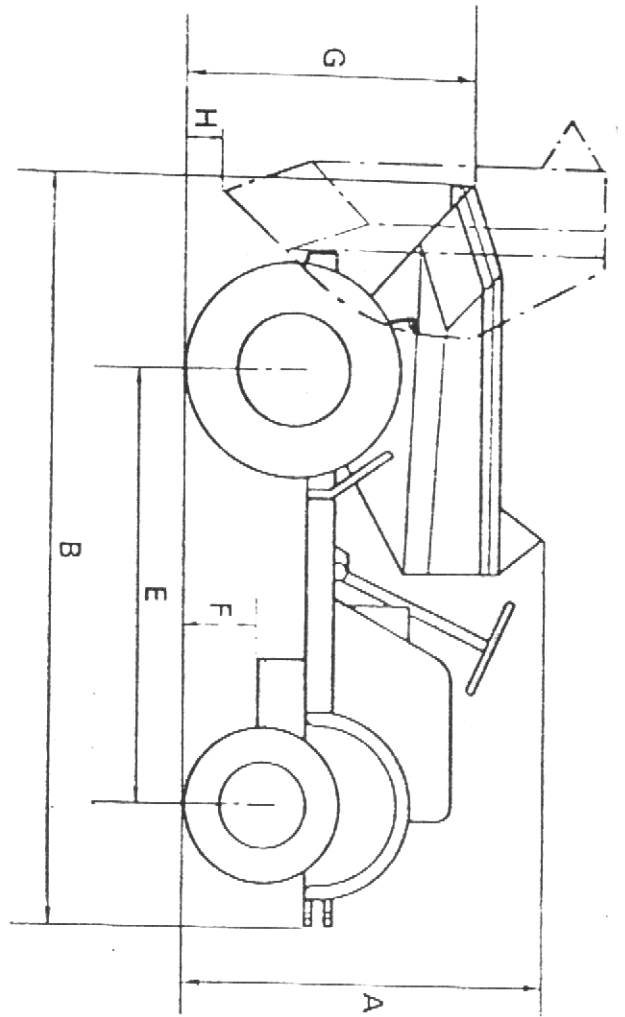

DIMENSIONS		Ft.	Ins.
A	OVERALL HEIGHT	4	10
B	OVERALL LENGTH	10	2½
C	OVERALL WIDTH	5	6
D	TRACK	4	10
E	WHEEL BASE	5	9
F	GROUND CLEARANCE	10	10
G	LOADING HEIGHT	3	9
H	DISCHARGE HEIGHT	1	4
I	ARTICULATION	1	2
J	TURNING CIRCLE	27	0
SKIP CAPACITIES:-		Ft.3	
WATER CAPACITY		22	
STRUCK CAPACITY		30	
HEAPED CAPACITY		37	

NETT WEIGHT 26¾ CWT.

MAX. PAYLOAD 3360 lbs. (1524 Kgs.)

RECOMMENDED LUBRICATING OILS

COMPANY	ENGINE	TRANSFER BOX & DRIVE AXLE	GEARBOX	WHEEL BEARINGS & OTHER GREASE POINTS	HYDRAULIC SYSTEM
(U.K.) ESSO (Overseas)	ESSOLUBE HDX 20W ESSOLUBE HDX 30 ESSOLUBE HDX 20W ESSOLUBE HDX 10W	GEAR OIL GP 90/140 GEAR OIL GP 140 GEAR OIL GP 90/140 GEAR OIL GP 80	ESSOLUBE HDX 30 ESSOLUBE HDX 30	BEACON 2 BEACON 2	NUTO H44 NUTO H 54 NUTO H 44 NUTO H 40
(U.K.) CASTROL	DEUSOL CRB 20 DEUSOL CRB 30 DEUSOL CRB 20 DEUSOL CRB 10	DEUSOL GEAR EP 90 DEUSOL GEAR EP 140 DEUSOL GEAR EP 90 DEUSOL GEAR EP 80	DEUSOL CRB 30 DEUSOL CRB 30	CASTROL SPHEEROL APT 2 CASTROL SPHEEROL APT 2	CASTROL HYSPIN AWS 32
(U.K.) SHELL (Overseas)	ROTELLA SX OIL 20/20W ROTELLA SX OIL 30 ROTELLA SX OIL 20/20W ROTELLA SX OIL 10W	SPIRAX 90 EP SPIRAX 140 EP SPIRAX 90 EP SPIRAX 80 EP	ROTELLA SX OIL 30 ROTELLA SX OIL 30	RETINAX A RETINAX A	TELLUS OIL 27
(U.K.) BP (Overseas)	VANELLUS M20W VANELLUS M30 VANELLUS M20W VANELLUS M10W	GEAR OIL SAE 90 EP GEAR OIL SAE 140 EP GEAR OIL SAE 90 EP GEAR OIL SAE 80 EP	VANELLUS M30 VANELLUS M30	ENERGREASE L2 ENERGREASE L2	ENERGOL HLP 65
(U.K.) MOBIL (Overseas) ALL TEMPERATURES	DELVAC 1220 DELVAC 1230 DELVAC 1220 DELVAC 1210 DELVAC SPECIAL 10W-30	MOBILUBE HD 90 MOBILUBE GX 90 MOBILUBE HD 140 MOBILUBE GX 140 MOBILUBE HD 90 MOBILUBE GX 90 MOBILUBE HD 80 MOBILUBE GX 80	DELVAC 1230 DELVAC 1230	MOBILGREASE MP MOBILGREASE SUPER	DTE 24
(U.K.) WALKERS CENTURY Overseas	CENTLUBE HD 20 CENTLUBE HD 30 CENTLUBE HD 20 CENTLUBE HD 10	CENTURY EP 90 CENTURY EP 140 CENTURY EP 90 CENTURY EP 80	CENTLUBE HD 30 CENTLUBE HD:30	REGULUS A2 REGULUS A2	CENTURY PWLA HYD OIL CENTURY PWLA HYD OIL

IN THE UNLIKELY EVENT OF THE ABOVE OILS NOT BEING AVAILABLE
EQUIVALENT OILS SUPPLIED BY A REPUTABLE MANUFACTURER MAY BE USED

SPARE PARTS SECTION

LIST OF CONTENTS

TITLE	PAGE NO.
CHASSIS	17-18
SKIP & FRAME	19-20
CLUTCH ASSEMBLY	21
GEARBOX	22-25
DRIVE AXLE	26-29
PROPSHAFT & COUPLING	30
DRIVE WHEELS/FRONT	31
STEERING WHEELS/REAR	32
STEERING AXLE	33-34
PEDALS & CONTROLS	35-36
STEERING GEAR (CAM & ROLLER)	37-38
STEERING GEAR (RECIRCULATING BALL)	39-40
BRAKE PIPES & FITTINGS	41
MASTER CYLINDER	42
BRAKE CALIPER	43
HANDBRAKE CALIPER	44

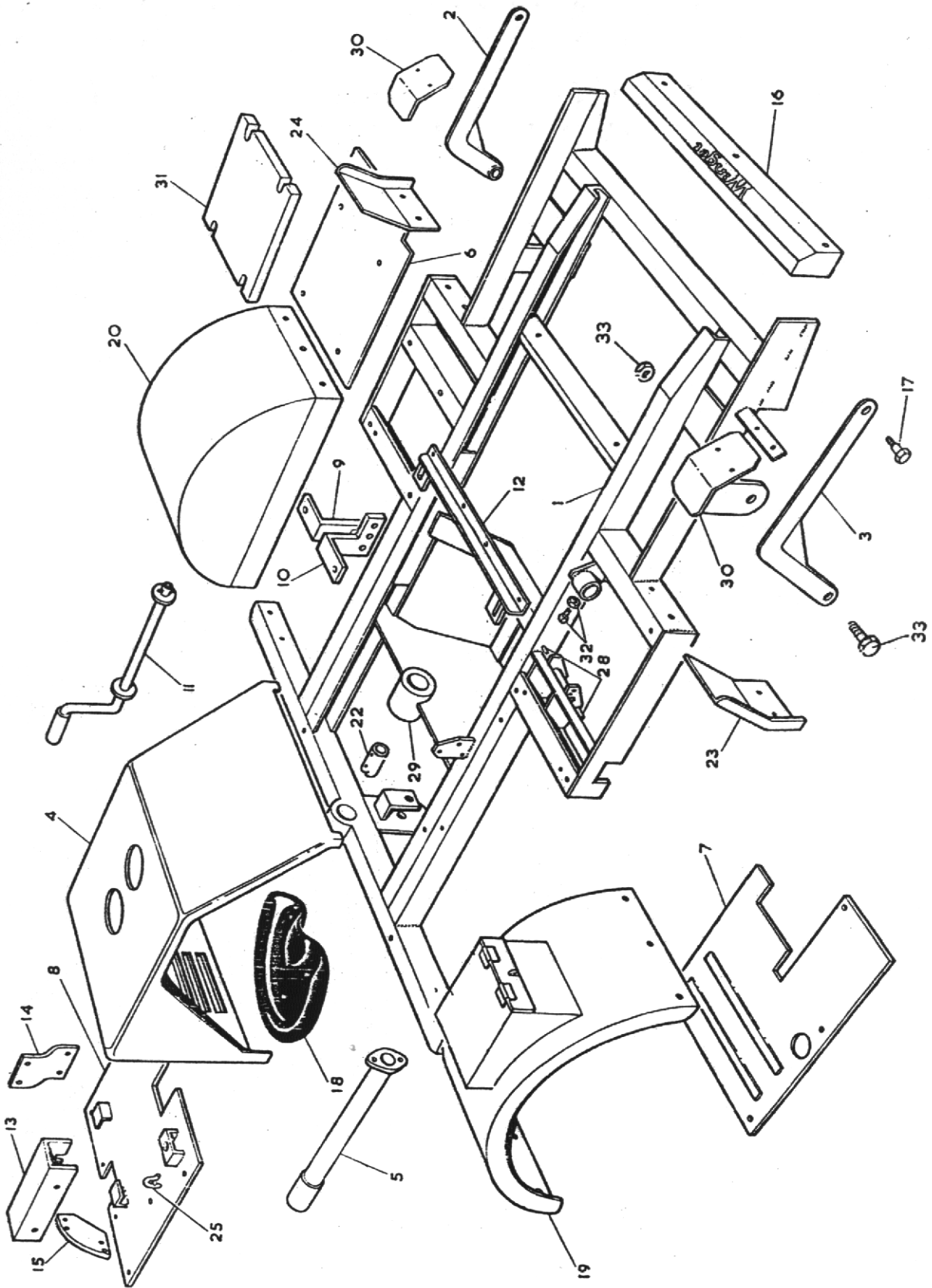

CHASSIS, WINGS etc.

Item No.	Part No.	Description	No. Off
1	4S 100	Chassis Frame (Petter)	1
1B	4S 123	Chassis Frame (Lister)	1
2	5S/106N	Skip Radius Rod L.H.	1
3	5S/106O	Skip Radius Rod L.H.	1
4	F.510	Engine Cover (Petter)	1
4B	4S/122	Engine Cover (Lister)	1
5	5S 111	Exhaust Pipe	1
6	F.529	Cover (L.H. Side)	1
7	4S 105	Cover (Driver's Side)	1
8	4S 109	Cover Rear (Petter)	1
8B	4S 124	Cover Rear (Lister)	1
9	4S 104	Gearbox Support L.H.	1
10	4S 104A	Gearbox Support R.H.	1
11	F.534	Starting Handle (Petter)	1
11A	L.294	Starting Handle (Lister)	1
12	5S 110	Engine Cover Support (Petter)	1
12A	5S 123	Engine Cover Support (Lister)	1
13	F.539	Engine Fuel Tank Support (Top) Petter	1
14	F.540	Engine Fuel Tank Support (Bottom) Petter	1
15	F.541	Engine Filter Bowl Support Petter	1
16	C.147	Ballast Weight (Front)	1
17	C.176	Skip Radius Rod Bolt	2
* 18	20072.A01	Seat	1
19	40059.A01	Rear Mudwing (Driver's Side)	1
20	L.252B	Rear Mudwing(L.H. Side)	1
22	L.259L	Starter Dog Lister	1
22A	L.259P	Starter Dog Petter	1
23	L.283	R.H. Mudflap Drive Wheel Driver's Side	1
24	L.283	L.H. Mudflap Drive Wheel L.H. Side	1
25	L.287A	Starting Handle Clip and Spring	1
28	WB.0808	Accelerator Holder Bush	2
29	F.500	Starter Dog Shroud	1
31	C.181	Ballast Weight (Side)	1
32		Locking Nuts and Bolts M12 x 25	2
33		Bolt M20 x 60 mm. long and locknut	2
*	69S.2C	Setscrew 5/16" UNC x 3/4"	4
	41S.4A	Washer - Lock 5/16"	4
	10566.A01	Grommet	1

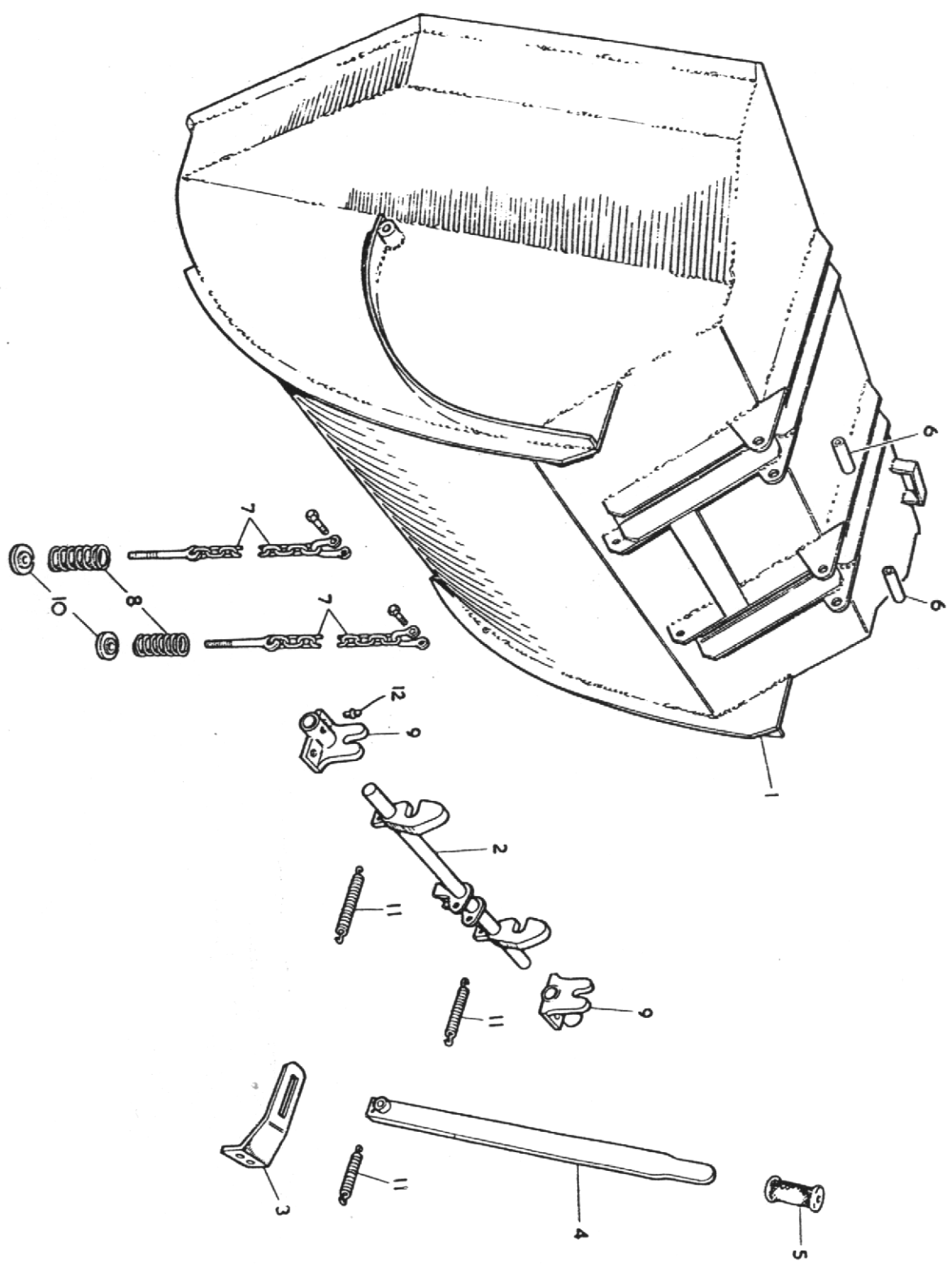

DUMP SKIP & OPERATING GEAR

<i>Item No.</i>	<i>Part No.</i>	<i>Description</i>	<i>No. Off</i>
1	4S 101	Skip	1
2	F.526	Skip Catch Hook	1
3	F.527	Catch Gate	1
4	F.528	Catch Handle	1
5	C.172	Handle Grip	1
6	C.140A	Skip Catch Tube	2
7	L.255	Skip Stub Chain	2
8	L.256B	Skip Stud Spring	2
9	L.275	Skip Catch Bracket	2
10	L.303	Skip Stub Spring Boss	2
11	C.173B	Spring	3
12	TST	Grease Nipple	2

FLYWHEEL AND CLUTCH ASSEMBLY

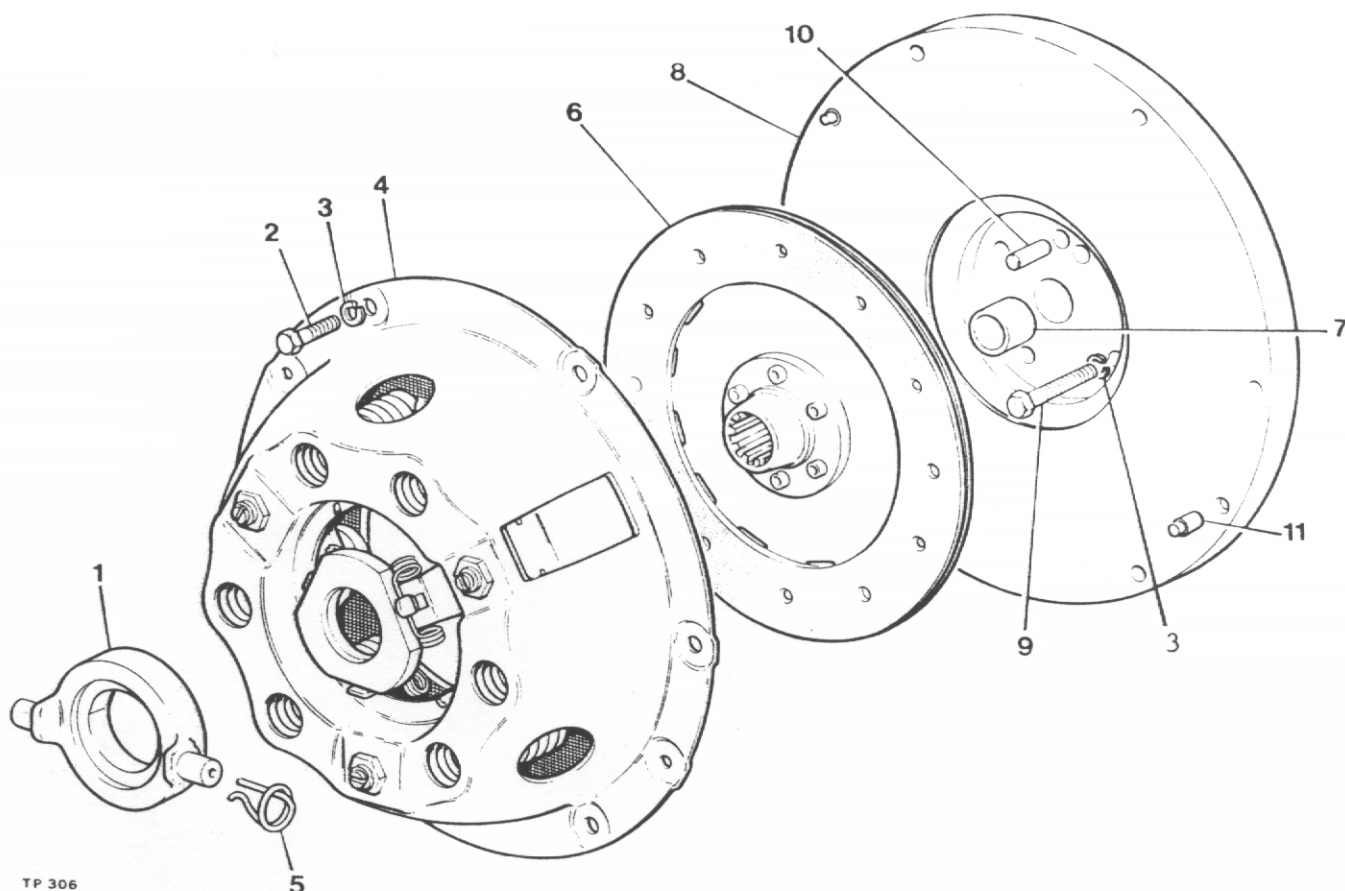

TP 306

Item No.	Part No.	Description	Qty.
1	10579A01	Clutch Release Bearing	1
2	28S02D	Screw Set	6
3	41S04	Washer Spring	10
4	10597A01	Cover Assembly	1
5	10579A101	Retainer Spring	2
6	10598A02	Drive Plate	1
7	10580A0101	Bush	1
8	10580A02	Flywheel Assembly (comprises of items 7, 8, & 11)	1
9	1S02C	Bolt, Petter PH Engine (drill for locking wire)	4
9A	6S02B	Bolt, Lister Engine (drill for locking wire)	4
10	C321	Dowel	1
11	10580A0102	Dowel	2
	10948A02	Clutch Kit (comprises of items 1, 4, 5 & 6)	1

It is recommended that instead of drilling the head of the bolts (item 9) for locking wire that one of each of tabwashers part no's 10531A02 and 10531A03 are used to prevent the bolts working loose.

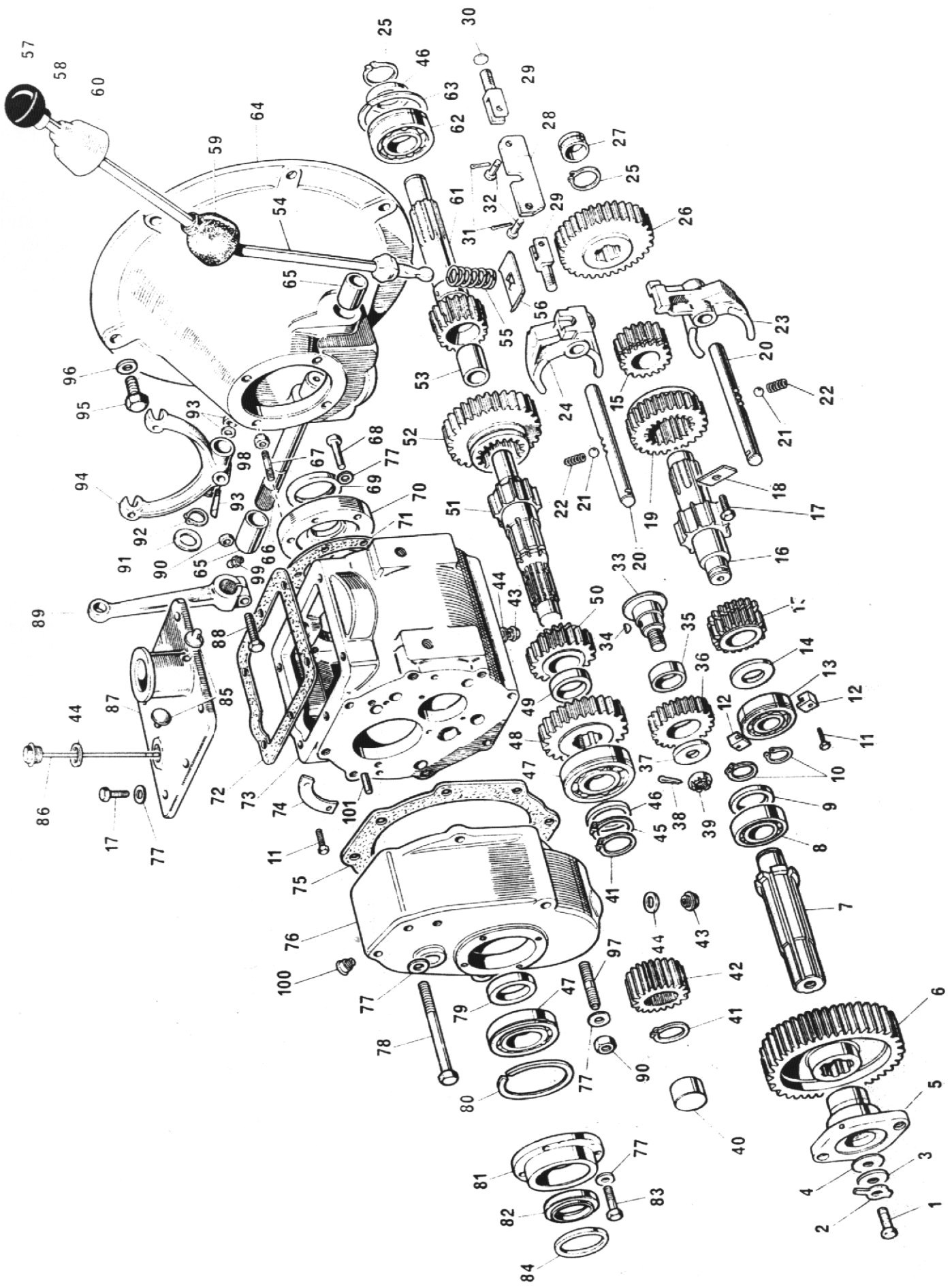

GEARBOX 40M/824

Item No.	Part No.	Description	No. Qty
1	USF55	Screw, Coupling	1
2	CM2050	Lockwasher	1
3	CM2123	Washer, Coupling	1
4	40M/340	Washer, Fibre	1
*5	40M/383	Flange, Drive (Type 70) 9/16" Bolts <i>SEE NOTE BELOW</i>	1
6	40M/316	Gear, Driven	1
7	40M/313	Shaft, Output	1
8	40M/327	Bearing	1
9	40M/325	Spacer, Bearing	1
10	40M/148	Circlip	2
11	USF11	Screw, Bearing Retaining	3
12	40M/299	Clip, Layshaft Bearing	2
13	40M/146	Bearing, Rear Layshaft	1
14	40M/130	Spacer, Bearing	1
15	40M/114	Gear, Reverse Speed	2
16	40M/118	Layshaft	1
17	USF21	Screw, Top Cover & Lock Strip	13
18	40M/136	Strip, Locking (Selector)	1
19	40M/116	Gear, Second Speed Sliding	1
20	40M/135	Shaft, Selector	2
21	CP1077	Ball, Detent (CM2051 Prior To S/No 4616)	2
22	CM2103	Spring, Detent	2
23	40M/501	Fork, Selector (First & Reverse)	1
24	40M/502	Fork, Selector (Second & Third)	1
25	CM2053	Circlip, Primary Shaft	3
26	40M/360	Gear, First Reduction	1
27	40M162	Bush, Layshaft	1
28	40M/505	Plate, Interlock	1
29	40M/231	Stud, Interlock	2
30	CM2113	Disc, Sealing	3
31	40M/244	Split Pin, Interlock	2
32	40M/232	Clevis Pin, Interlock	2
33	40M/119	Shaft, Reverse Pinion	1
34	40M/222	Key, Reverse Pinion Shaft	1
35	40M/161	Bush, Reverse Pinion	1
36	40M/111 S/A	Pinion, Reverse C/W Item 35	1
37	40M/155	Washer, Reverse Pinion Shaft	1
38	CP1004	Pin, Split	1
39	UN507	Nut, Reverse Spindle	1
40	40M/346	Roller, Needle	1
41	40M/347	Circlip	2
42	40M/350	Gear, Drive	1
43	CP1002	Plug, Drain	2
44	CP1068	Washer, Drain Plugs & Dipstick	3
45	40M/348	Circlip	1
46	40M/174	Spacer, Bearing	2
47	CM2052	Bearing, Rear Mainshaft	2
48	40M/110	Gear, Output	1
49	40M/128	Spacer, Output Shaft	1
50	40M/113	Gear, Second Speed	1
51	40M/345	Shaft, Main	1
* SA	40M223	Drive Flange (1/2" Bolts)	1

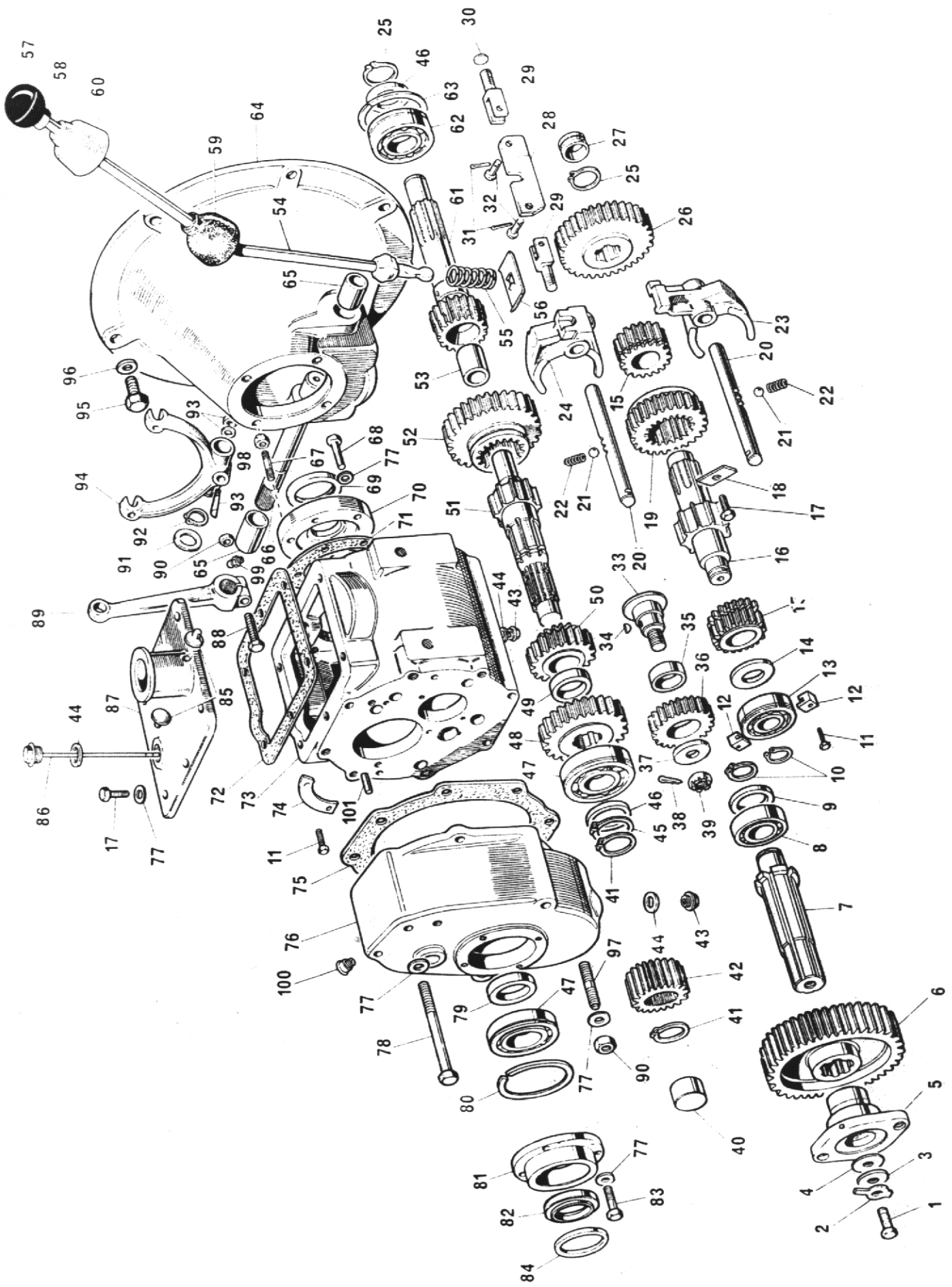

GEARBOX 40M/824

Item No.	Part No.	Description	No. Off
52	40M/115	Gear, First Speed	1
53	40M/513	Bearing, Primary Shaft	1
54	40M/334A	Lever, Gear	1
55	40M/367	Spring, Gear Lever	1
56	40M/245	Plate, Gear Lever Retaining	1
57	40M/133	Knob, Gear Lever	1
58	UN512	Nut, Gear Lever	1
59	40M/129	Cover, Gear Lever	1
60	40M/377	Cover, Protective	1
61	40M/117 S/A	Shaft, Primary C/W Item 53	1
62	40M/143	Bearing, Input	1
63	40M/252	Ring, Snap	1
64	40M/392	Housing, Clutch	1
65	CM2179	Bush, Clutch Cross Shaft	2
* 66	40M/394	Cross Shaft, Clutch SEE NOTE BELOW	1
67	40M/177	Stud	6
68	UBF71	Bolt, Front Cover	4
69	40M/150	Oil Seal, Input	1
70	40M/126	Cover, Front	1
71	40M/172	Joint, Front Cover	1
72	40M/169	Joint, Top Cover	1
73	40M/101/N	Casing, Gearbox	1
74	40M/141A	Retainer, Large Bearing	1
75	40M/661	Joint, Reduction Housing	1
76	40M/660	Housing, Reduction	1
77	W104	Washer, Front Cover, Top Cover Lock Strip & Reduction Housing	25
78	UBF19L	Bolt, Reduction	4
79	40M/320	Spacer, Output Shaft	1
80	CM2060	Retainer, Bearing	1
81	40M/622 S/A	Housing, Rear Oil Seal C/W Item 82	1
82	40M/167	Oil Seal, Rear	1
83	USF3L	Screw Reduction Housing	8
84	CM2201	Excluder, Dust	2
85	40M/254	Pad, Gear Lever	2
86	40M/153	Dipstick	1
87	40M/220	Cover, Gearbox	1
88	UBF91	Bolt, Clutch Lever	1
89	CM2090	Lever Clutch Release	1
90	UN501	Nut, Clutch Lever & Reduction Housing	3
91	40M/398	Washer, Cross Shaft	1
92	CP1006	Circlip, Cross Shaft	1
93	CM2084/SA	Cotter, Nut & Washer	1
94	CM2083	Fork, Clutch Release	1
95		Bolt	6
96		Washer	6
97	40M/329	Stud	2
98	UNL106	Nut, Clutch Housing	6
99	CP1069	Nipple, Grease (Straight)	1
100	CM2106	Breather	1
101	40M/656	Dowel	1
* 66A	40M 153	Clutch Cross Shaft (old type)	1

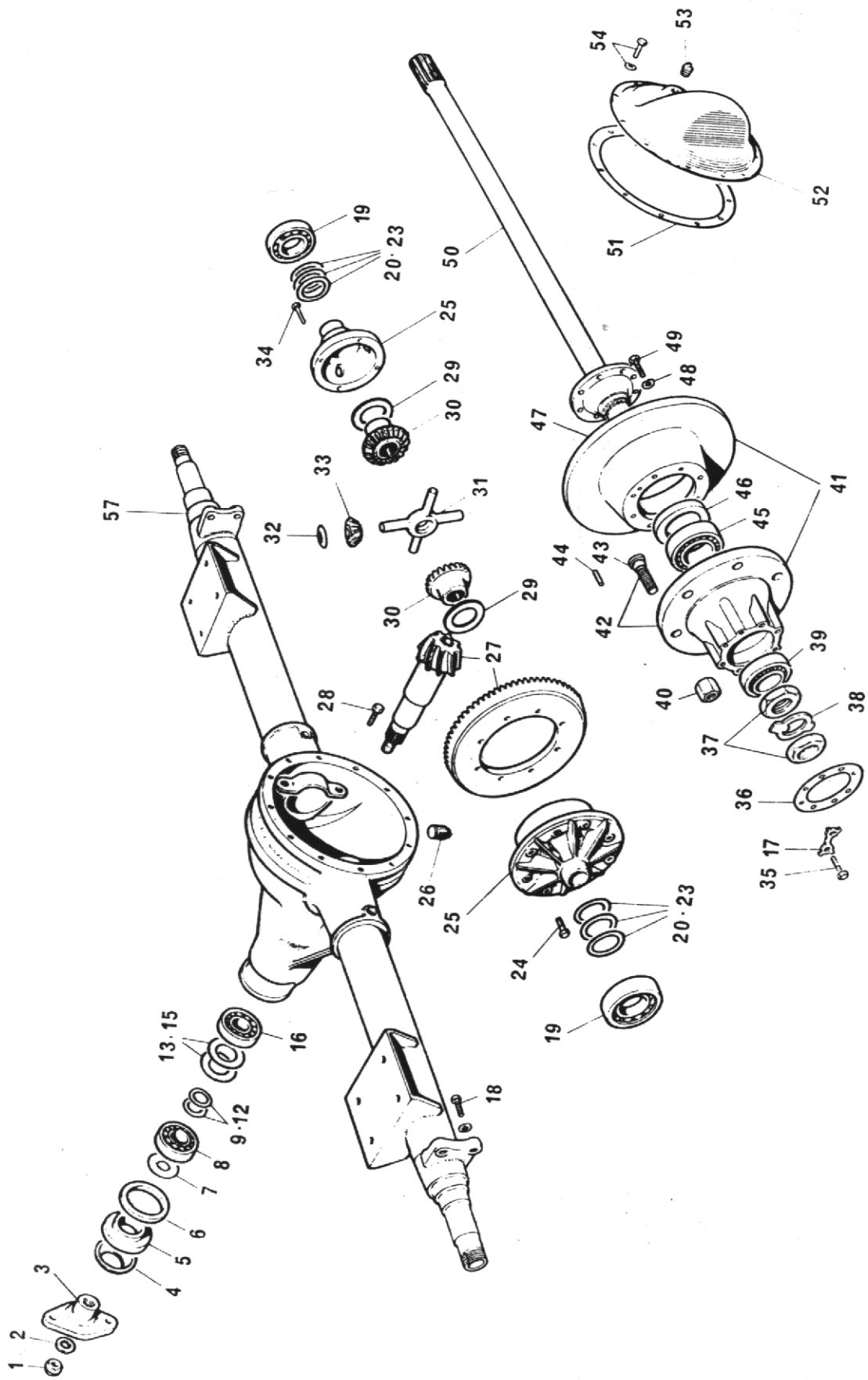

DRIVE AXLE 5HA 001-239

Item No.	Part No	Description	Qty. Or
1	12LN-NF9	Pinion Nut	1
2	12W-24	Pinion Nut Washer	1
3	5HA-102-8	Companion Flange Assembly Type 70 4.5/16" Ctrs.	1
4	2HA-021	Companion Flange Dust Shield	1
5	2HA-019	Pinion Oil Seal	1
6	2HA-020	Pinion Oil Seal Gasket	1
7	2HA-036	Pinion Oil Slinger	1
8	5HA-022	Pinion Bearing Outer	1
9	5HA-039	Pinion Adjusting Shim Outer (.003") as req'd	2
10	5HA-040	Pinion Adjusting Shim Outer (.005") as req'd	2
11	5HA-041	Pinion Adjusting Shim Outer (.010") as req'd	2
12	5HA-042	Pinion Adjusting Shim Outer (.030") as req'd	2
13	5HA-043	Pinion Adjusting Shim Inner (.003") as req'd	2
14	5HA-044	Pinion Adjusting Shim Inner (.005") as req'd	2
15	5HA-045	Pinion Adjusting Shim Inner (.010") as req'd	2
16	5HA-023	Pinion Bearing Inner	1
17	5HA-074-3	Axle Shaft Flange Lockstrap	8
18	7BNF-22-B	Brake Caliper Mounting Bolt	4
18A	7W-16	Caliper Mounting Packing Washer	4
18B	7W-14	Caliper Mounting Washer	4
18C	5HA-138	Caliper Adjusting Shim (.003")	A/R
18D	5HA-139	Caliper Adjusting Shim (.005")	A/R
18E	5HA-140	Caliper Adjusting Shim (.020")	A/R
18F	5HA-141	Caliper Adjusting Shim (.030")	A/R
19	5HA-024-1	Differential Bearing	2
20	5HA-046	Differential Bearing Shim (.003")	2
21	5HA-047	Differential Bearing Shim (.005")	2
22	5HA-048	Differential Bearing Shim (.010")	2
23	5HA-049	Differential Bearing Shim (.030")	2
24	5HA-075-2	Drive Gear Screw	12
25	5HA-006-1	Differential Case	1
	* 5HA-082-2	Differential Case Assembly	1
	* 5HA-082-11	Differential Case Assembly (From Serial No. N70/546)	1
26	HA-059	Drain & Filler Plugs	2
27	5HA-105-11	Drive Gear and Pinion Assembly including Items 1, 24 & 58	1
28	8BNC.36	Differential Bearing Cap Screw	4
28A	8LW-115	Differential Bearing Cap Lockwasher	4
29	5HA-038-1	Differential Case Side Gear Thrustwasher	2
30	5HA-007-4	Differential Side Gear	4
	5HA-007-3	Differential Side Gear (from Serial No. N70/546)	4
31	5HA-012-2	Differential Pinion Mate Shaft	1
32	5HA-037-1	Pinion Mate Thrustwasher	4
33	5HA-008-4	Pinion Mate	2
	5HA-008-3	Pinion Mate (from Serial No. N70/546)	2
34	5BNC2 BA	Differential Case Screw	8
34A	5HA-097	Differential Case Lockstrap	4
35	7BNC-20A	Axle Shaft Flange Driving Bolt	16
36	10HA-031	Axle Shaft Flange Gasket	2
37	32N-NF4	Wheel Bearing Locknut	4
38	8HA-091-2	Wheel Bearing Locking Washer	2
39	8HA-025-6	Wheel Bearing Outer	2
40	T.23	Wheel Nut	12
41	10HA-028-23	Hub and Disc Assembly	2
42	10HA-028-24	Wheel Hub with Studs	2

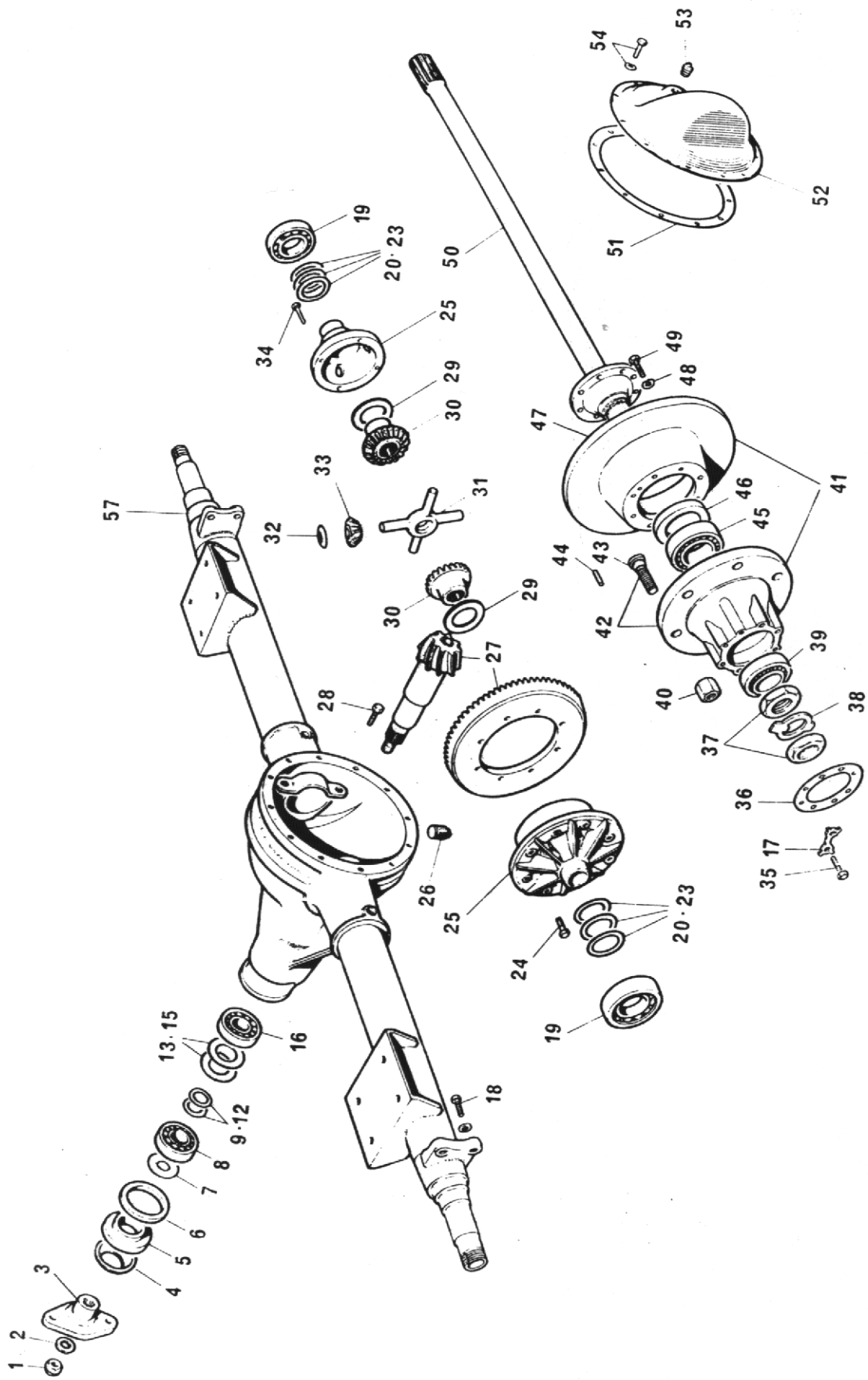

DRIVE AXLE Cont'd

<i>Item No.</i>	<i>Part No.</i>	<i>Description</i>	<i>Qty</i>
43	10HA-055-5	Wheel Stud	12
44	12RP-16	Brake Disc Dowel	4
45	8HA-025-5	Wheel Bearing Inner	2
46	5HA-032-6	Hub Oil Seal	2
47	10HA-136	Brake Disc	2
48	6LW-105	Brake Disc Retaining Washer	10
49	6BNF-21	Brake Disc Retaining Screw	10
50	5HA-005-75	Axle Shaft	2
51	5HA-026	Gear Carrier Cover Gasket	1
52	5HA-010-14	Gear Carrier Cover	1
53	HA-059	Filler Plug	1
54	6B-NC-10	Cover Screw and Washer	10
57	5HA-101-86	CARRIER TUBE	1

7819

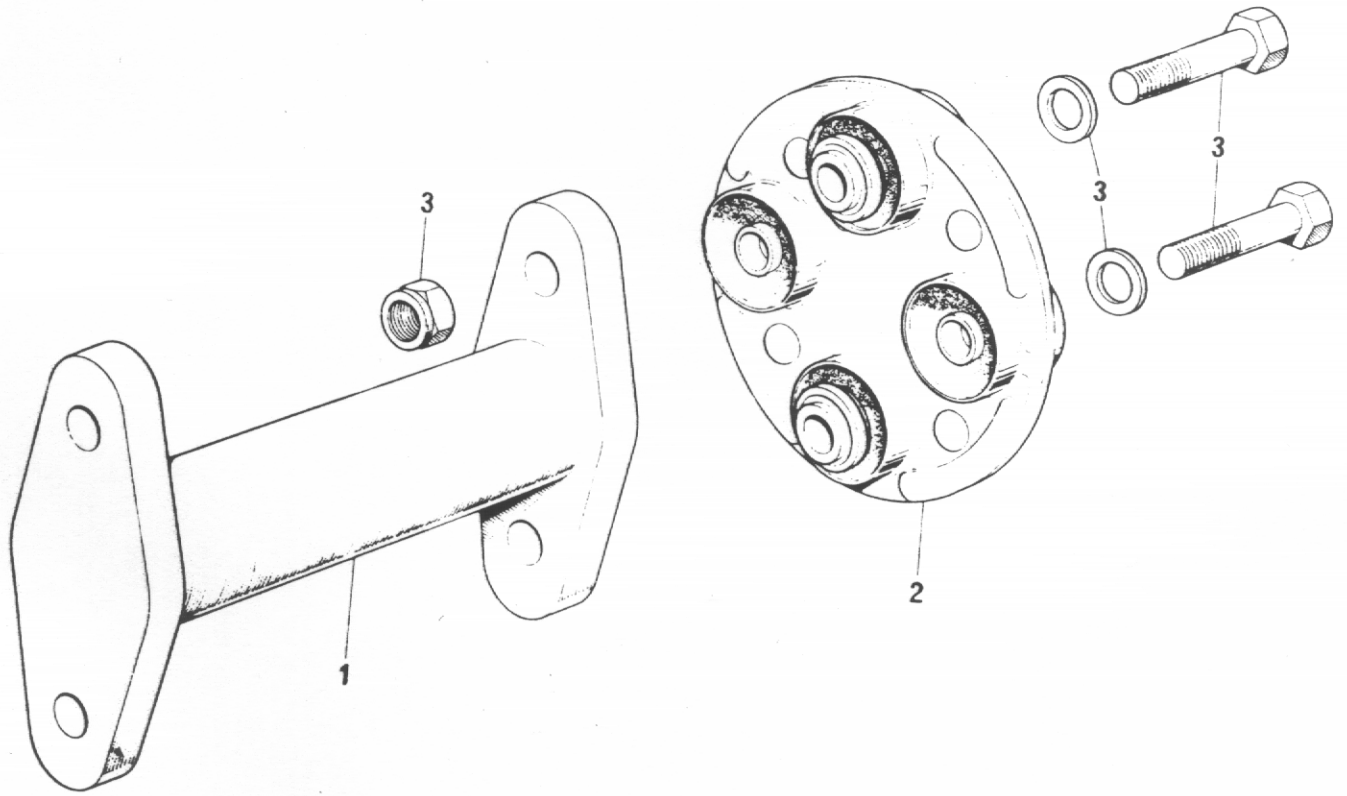

PROPSHAFT

Item No.	Part No.	Description	Qty.
1	5S10270	Prop shaft tube (9/16" bolts, 4. 5/16" centers)	1
1	5S102/65	Prop shaft tube (alternative)	1
2	10323A01	Coupling	2
3	10203A	Coupling bolt, washer and nut (9/16")	8

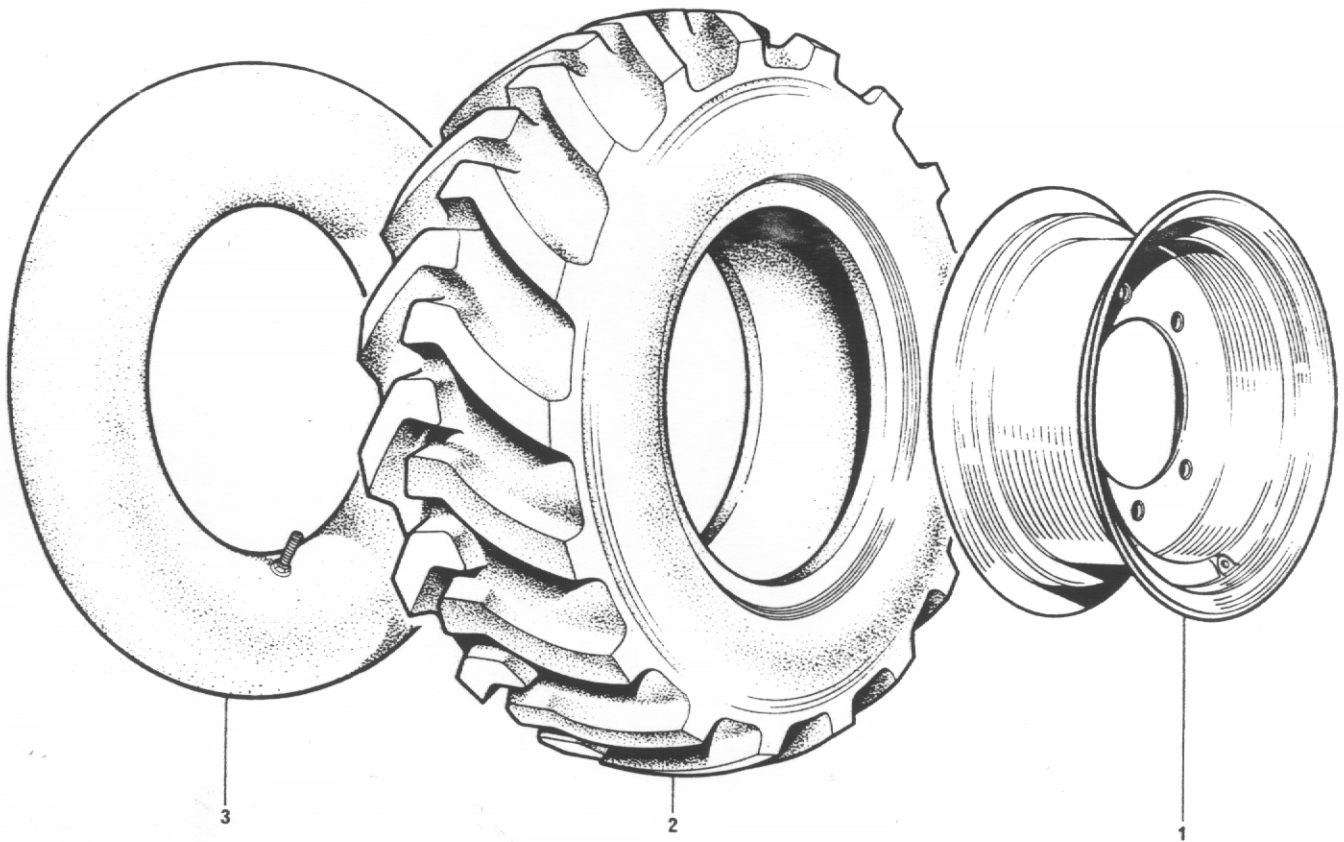

DRIVE WHEELS AND TYRES

Item No.	Part No.	Description	Qty.
1	24S16	R/H Wheel Assembly	1
1	24S15	L/H Wheel Assembly	1
2	30193A01	Wheel rim 9 x 18	2
2	20S01	Tyre 10.5 x 18-6 ply	2
3	23S04	Tube 10.5 x 18	2

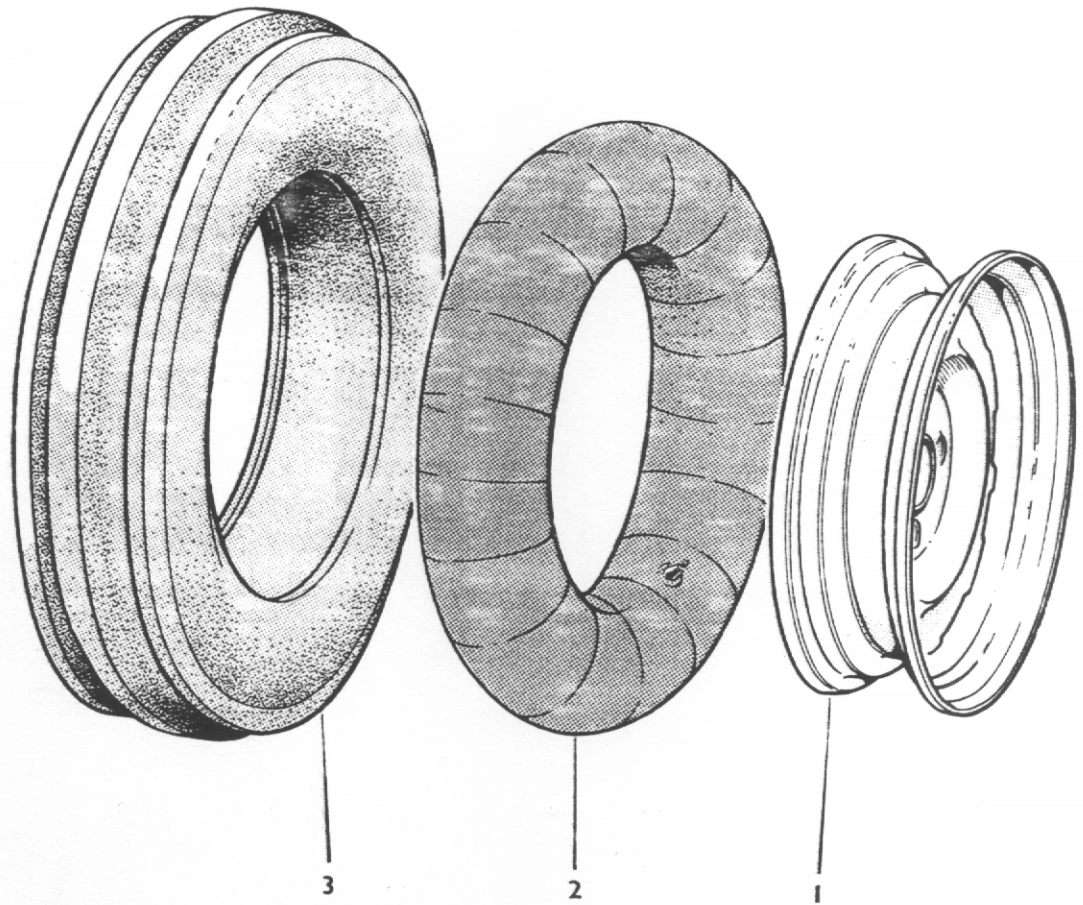

STEERING WHEELS AND TYRES

Item No.	Part No.	Description	Qty.
1	24S31	Steering wheel complete	2
2	30033A01	Wheel rim 4.00 x 16	2
3	23S02	Tube 6.00 x 16	2
	21S03	Tyre 6.00 x 16-4 ply	2

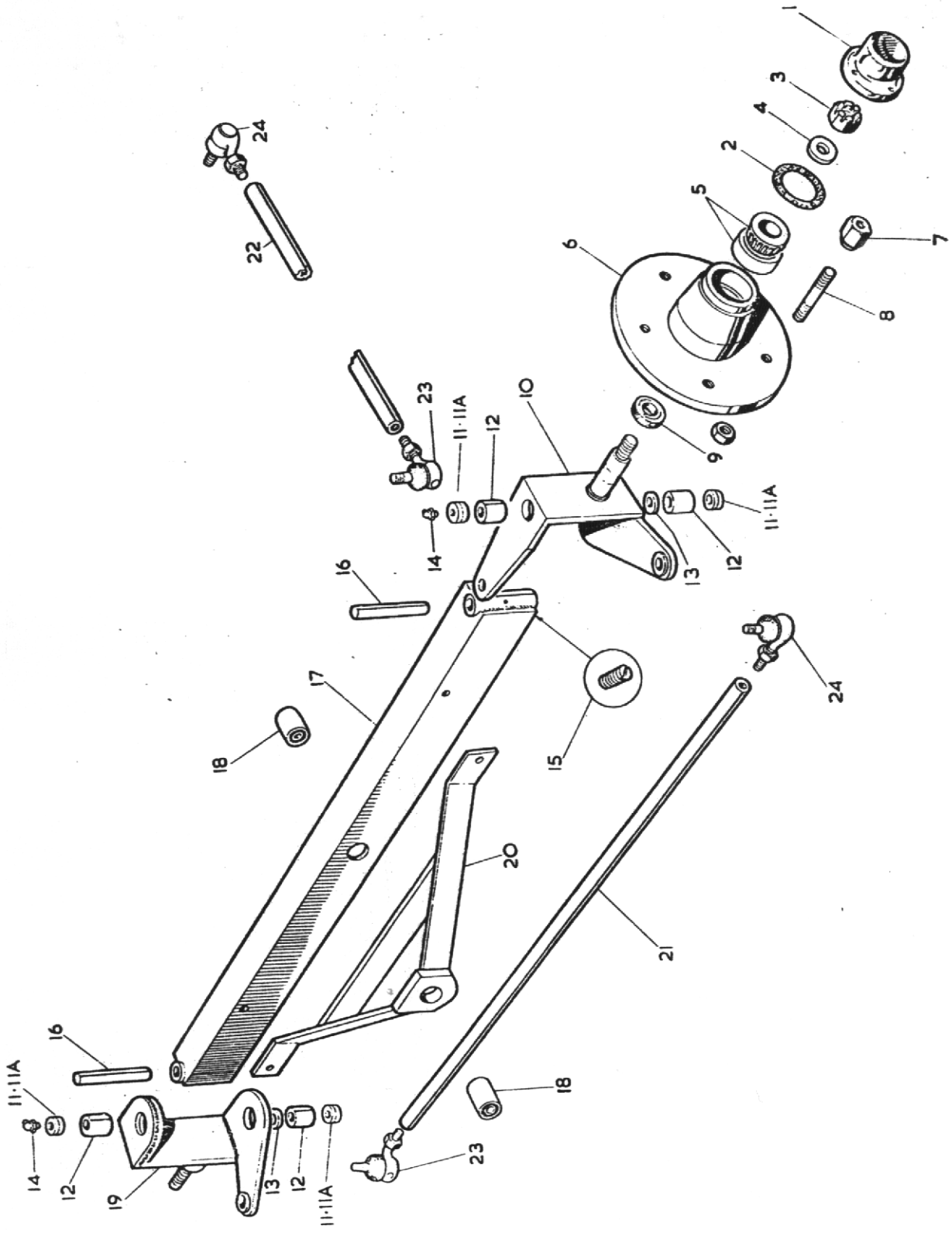

STEERING AXLE

<i>Item No.</i>	<i>Part No.</i>	<i>Description</i>	<i>No. Off</i>
1	R/344	Hub Cap	2
2	R/345	Hub Cap Gasket	2
3	R.305/A	Hub Nut	2
4	R.305/B	Hub Nut Washer	2
5	K.18690	Hub Bearing (Inner and Outer)	4
6	O190	Hub Assembly	2
7	10668.A01	Hub Wheel Nut	10
8	O190/S	Wheel Stud	10
9	R.343	Hub Bearing Oil Seal	2
10	F.505/OS	Stub Axle Assembly O/S	1
11	C.180 A & B	King Pin End Cap (Felt and Steel)	4
12	C.190	King Pin Bush	4
13	C.175	Thrust Washer	2
14	T.90	Grease Nipple	2
15	C111/A	King Pin Retaining Screw	2
16	R.320	King Pin	2
17	F.503	Steering Axle Beam	1
18	E.2245	Steering Axle and Stabiliser Bush	2
19	F.505/NS	Stub Axle Assembly N/S	1
20	L.262	Steering Axle Stabiliser	1
21	L 308	Track Rod	1
22	F.513	Drag Link	1
23	C.159/LH	Track Rod and Drag Link End L.H.	2
24	C.159/RH	Track Rod and Drag Link End R.H.	2

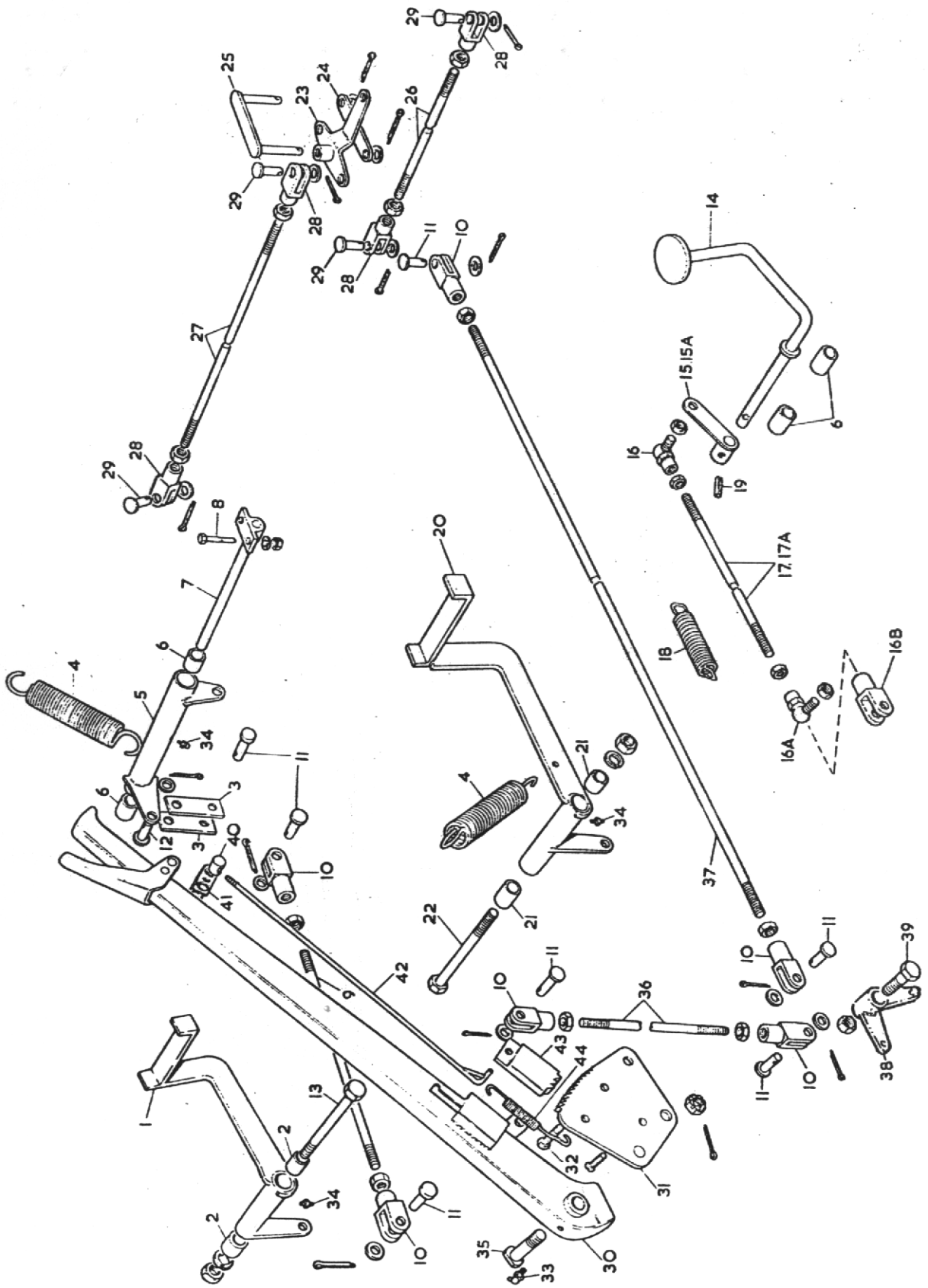

CLUTCH, HANDBRAKE & FOOTBRAKE ASSEMBLIES

Item No.	Part No.	Description	No. Off
1	F521	Pedal, Clutch	1
2	WB.1010	Bush, Clutch Pedal	2
3	F537	Link, Clutch Lever	2
4	C173-B	Spring, Return (Clutch and Footbrake Pedal)	2
5	F519	Lever, Clutch Transfer	1
6	WB0808	Bush, Transfer Lever (Clutch and Accelerator)	4
7	F519A	Rod, Clutch Transfer Lever	1
8		Nut and Bolt, $\frac{3}{8}$ "BSF x $1\frac{1}{2}$ " Long	1
9	F525	Rod, Clutch Adjusting $14\frac{1}{2}$ " x $\frac{3}{8}$ "BSF	1
10	C174 A	Clevis	6
11	C174 X	Clevis Pin	7
12	5ST-101	Clevis Pin	1
13		Nut and Bolt, $\frac{5}{8}$ "BSF x $4\frac{1}{2}$ " Long	1
14	C137	Pedal, Accelerator	1
15	F522	Lever, Accelerator (Petter	1
15A	C 308	Lever, Accelerator (Lister	1
16	C160-B	Ball End, Accelerator Rod	1
16A	C160-B	Ball End, Accelerator Rod (Petter	1
16B	C174-D	Fork End (Lister	1
17	5ST-22	Rod, Accelerator (Petter	1
17A	4S 166	Rod, Accelerator (Lister	1
18	C173-D	Spring, Return (Accelerator Rod)	1
19	C251-1	Pin, Tension	1
20	4S.102	Pedal, Footbrake	1
21	WB1212	Bush, Footbrake Pedal	2
22		Nut and Bolt $\frac{3}{4}$ " BSF x 8" Long	1
23	5ST.76	Arm, Compensator Lever	1
24	C189-A	Link, Compensator	1
25	C271	Compensator Link Assembly	1
26	L278A	Rod, Brake	1
27	4S.107	Rod, Handbrake	1
28	C174-C	Forkend	4
29	C174-Y	Clevis Pin	4
30	F517	Handbrake Lever Complete	1
31	F517A	Quadrant, Handbrake Lever	1
32		Bolt, 5/16" BSF x 1" Long	2
33	T90	Nipple, Grease (90°)	1
34	TS	Nipple, Grease (Straight)	3
35	F517B	Bolt, Handbrake Carrier	1
36	T 21C	Rod, Lever Connecting 3/8 BSF x 9" long	1
37	4S.108	Rod, Handbrake	1
38	LT292	Lever, Handbrake Transfer	1
39		Nut and Bolt, M16 x 80	1
40	000022/A	Pin, Latch Pivot Arm	1
41	14425A	Arm, Latch Pivot	1
42	10291C	Rod, Handbrake Rod	1
43	6266A	Pawl, Handbrake Pawl	1
44	12873-A	Spring, Handbrake	1

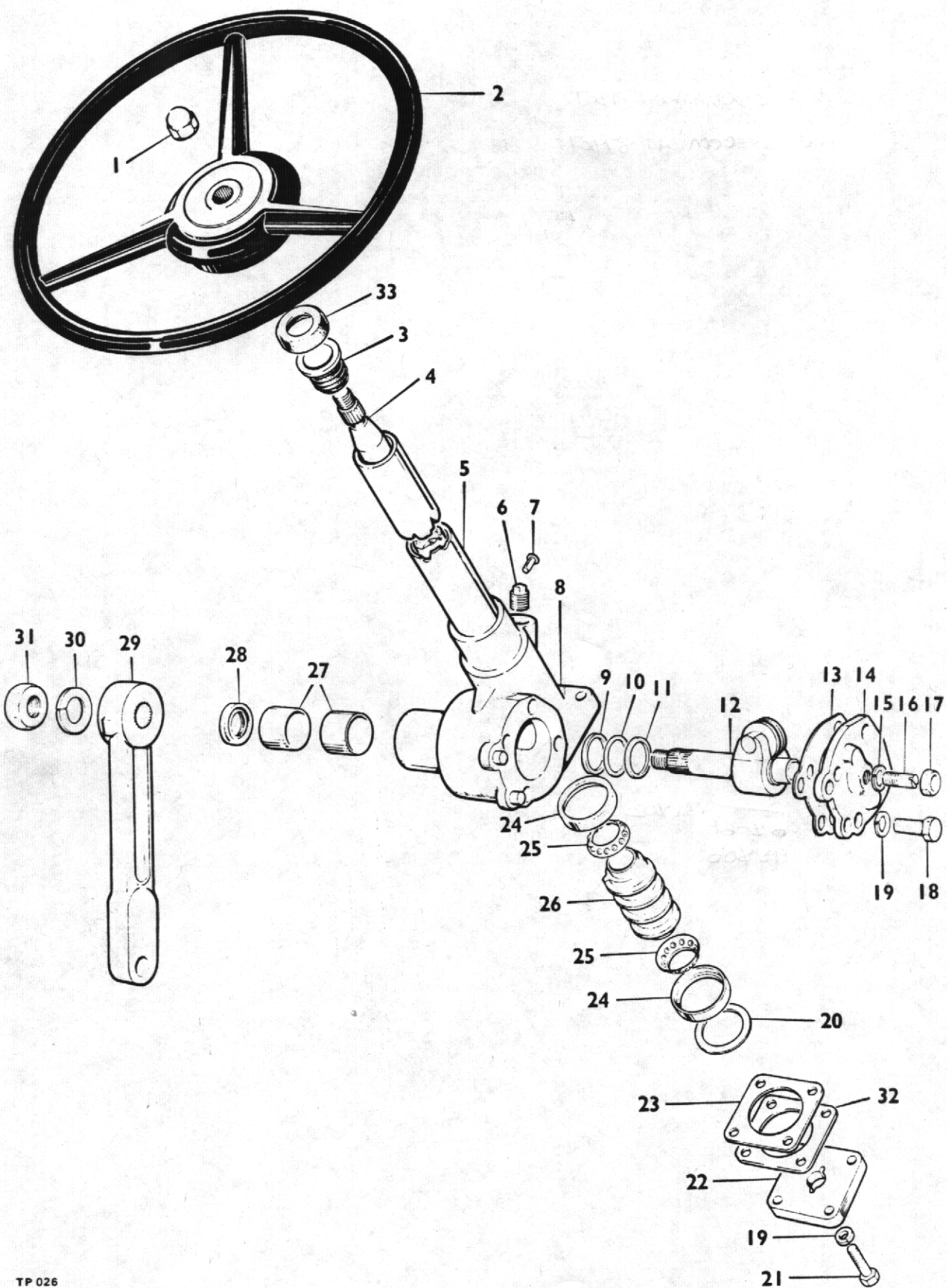

STEERING GEAR (CAM AND ROLLER TYPE)

Item No.	Part No.	Description	Qty.
	MGA 34849	Steering column assy. complete less items, 1,2 & 29	1
1	C 304	Steering wheel nut	1
2	347 K	Steering wheel	1
3	PA3904A	Column top bush	1
4	P5244/30"	Inner shaft	1
5	P3911/24"	Outer tube	1
6	S 9033	Oil plug	1
7	S 9166	Pin	1
8	PA4426	Steering box c/w item 14	1
9	P4151	Thrust washer	2
10	P 3308	Shim	A/R
11	P 4150	Thrust washer	2
12	PA5229/4¼"	Rocker shaft c/w roller	1
13	P3306A	Cover plate gasket	A/R
14	QA757	Cover plate and bush	1
15	S 999	Spring washer	1
16	P 4222	Adjuster screw	1
17	P 4221	Nut	1
18	S 9240	Setscrew	4
19	S 902	Spring washer	8
20	P3342	Washer	1
21	S 9300	Setscrew	4
22	P 3907	Bottom cap	1
23	P 3301/.005"	Shim	A/R
24	P 3341	Outer race	2
25	PA2733	Cage and balls	2
26	P 3340	Cam	1
27	P 3309	Bush	2
28	S 9242	Oil seal	1
29	M 29629	Drop arm	1
30	S 955	Spring washer	1
31	S 9332	Nut	1
32	P 3301G	Bottom cap liner	2
33	M33418	Inner column shroud	1

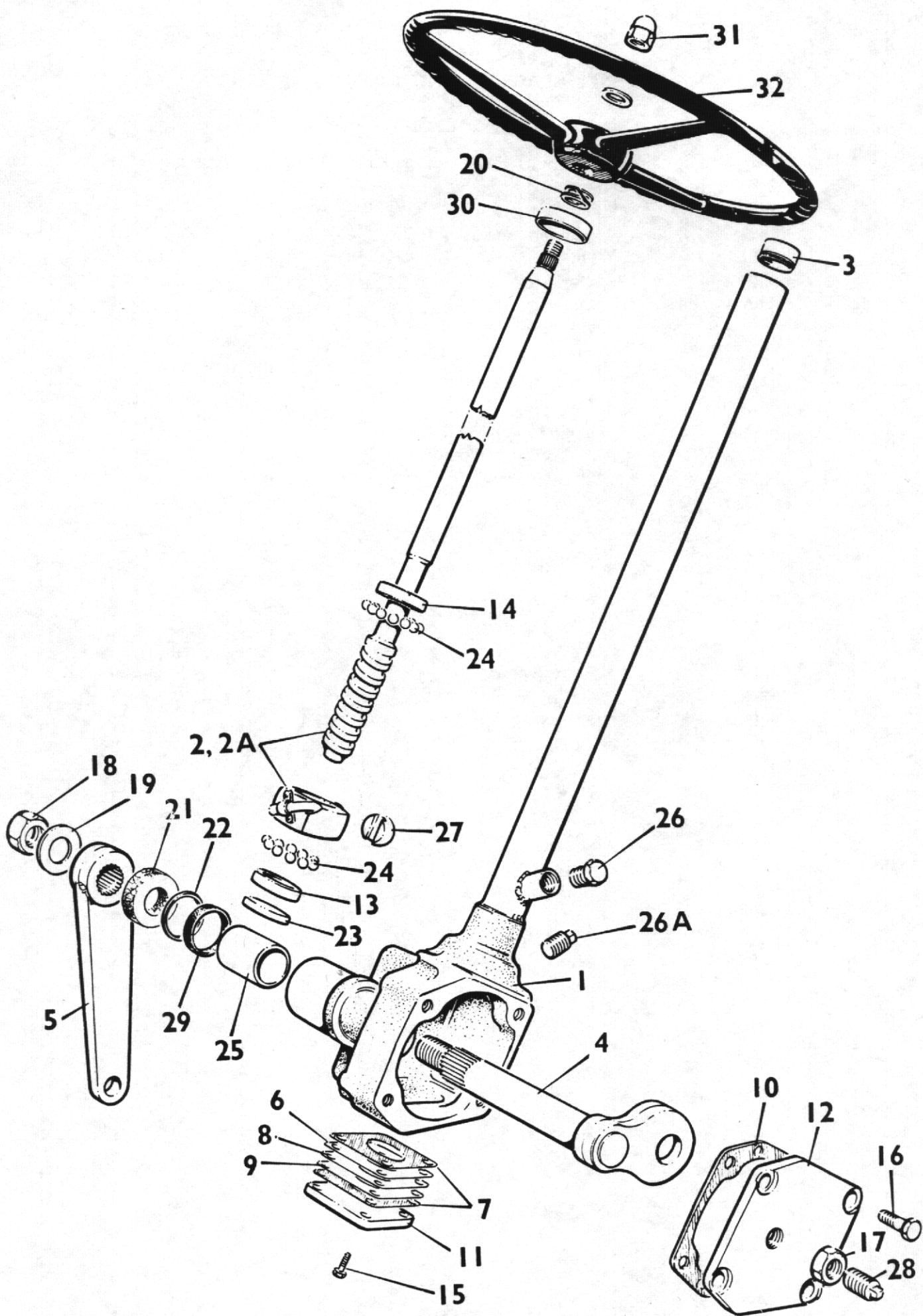

Switzer
L. J. Zink
10-10-10

STEERING GEAR (RECIRCULATING BALL TYPE)

Item No	Part No.	Description	Qty
	11-077	Steering gear complete (less items 5 & 32)	
1	SA-01-183	Box and Tube assembly	1
2	SA-02-269	Inner column assembly and main nut (700mm long)	1
2A	SA-02-277	Inner column assembly and main nut (750mm long)	1
3	SA-21-004	Bearing assembly	1
4	S-7-103	Rocker shaft	1
5	2SE90	Drop arm	1
6	S-10-14	End plate shim .005"	3
7	S-10-15	End plate gasket	2
8	S-10-42	End plate shim .002"	2
9	S-10-111	End plate shim .010"	2
10	S-10-191	Cover plate gasket	1
11	S-11-83	End plate	1
12	S-12-186	Cover plate	1
13	S-23-32	Ballrace (small)	1
14	S-23-33	Ballrace (large)	1
15	10-3-37	End Plate bolt	4
16	10-4-16	Cover Plate bolt	4
17	11-7-2	Rocker shaft adjuster screw nut	1
18	11-8-7	Rocker shaft nut	1
19	12-8-36	Rocker shaft tab washer	1
20	12-8-85	Spring	1
21	12-9-61	Drop arm felt washer	1
22	12-10-7	Oil seal retaining washer	1
23	12-12-26	Inner column packing plate	1
24	17-3-4	Steel ball	54
25	19-9-17	Rocker shaft bush	1
26	21-8-4	Oil Plug	1
26A	21-7-2	Oil Plug	1
27	24-5-5	Main nut roller	1
28	25-7-2	Rocker shaft adjuster screw	1
29	27-9-6	Oil seal	1
30	32-8-8	Dust cap	1
31	11-7-45	Dome nut	1
32	347K	Steering wheel	1

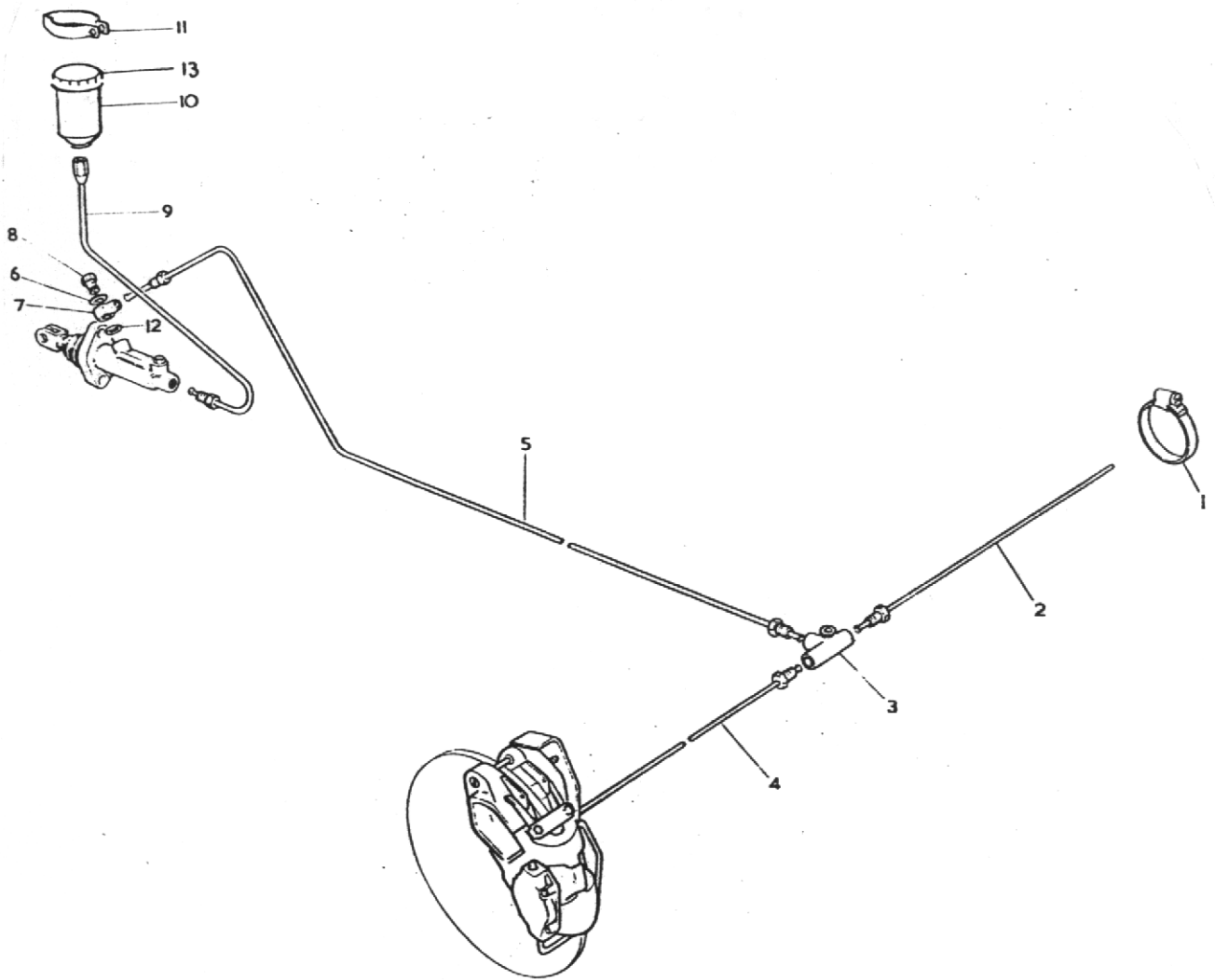

HYDRAULIC BRAKE SYSTEM

1	4S 133	Hose Clip	1
2	3508610W	Pipe (43")	1
3	64474341	Tee Piece	1
4	64476097	Pipe (18½")	1
5	64474263	Pipe (53")	1
6	378700	Washer	1
7	64474287	Banjo	1
8	376102W	Banjo Bolt	1
9	3424240W	Pipe (21")	1
10	64046158	Header Tank	1
11	64477544	Clip	1
12	378703	Washer	1
13	64474602	Cap	1

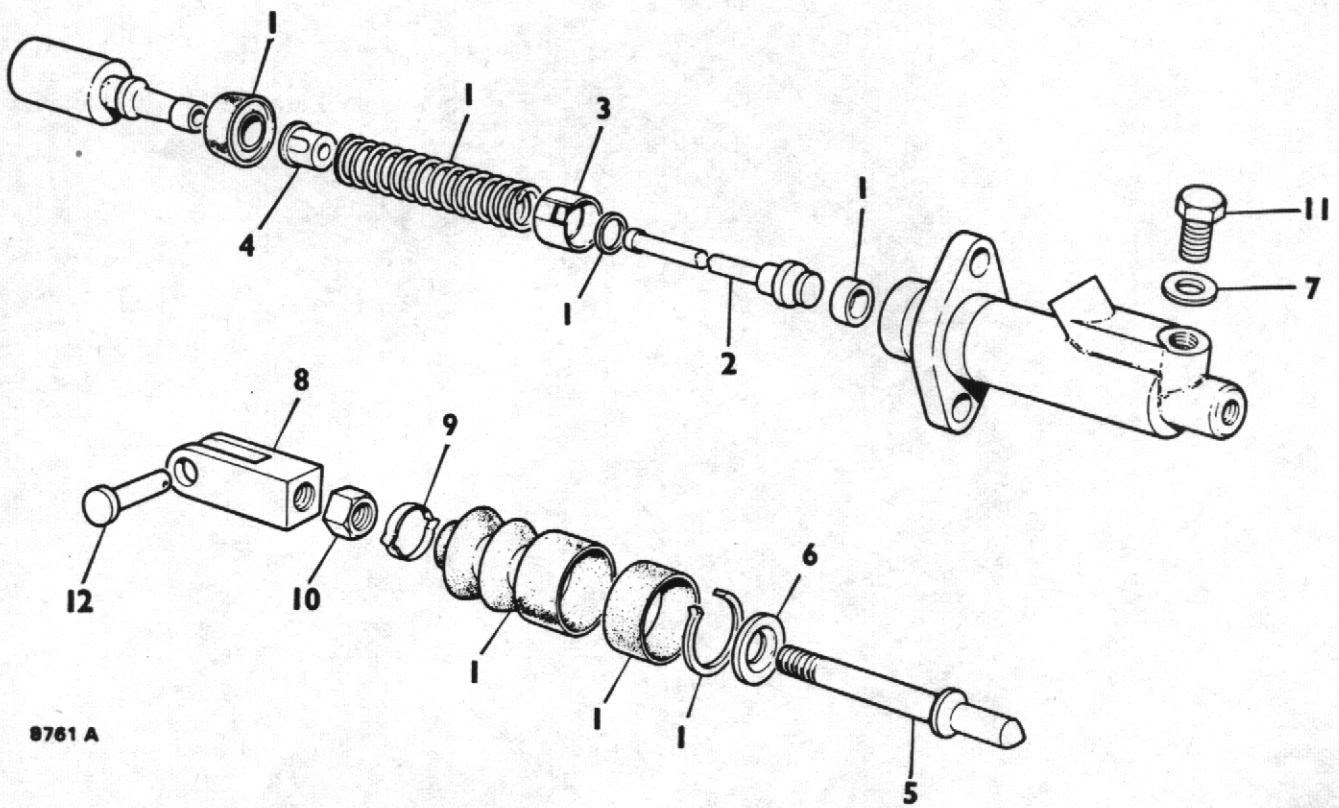

8761 A

MASTER CYLINDER ASSEMBLY

Item No.	Part No.	Description	Qty.
	64067970	Master Cylinder (Complete)	1
1	SP 1996/2	Seal Kit	1
2	378641	Valve Stem	1
3	318001	Valve Spacer	1
4	64673391	Valve Spring Retainer	1
5	351257 W	Push Rod	1
6	378242	Retaining Washer	1
7	378700	Washer	1
8	64671286	Clevis	1
9	378312	Dust Cover Retainer	1
10	64100052	Locknut	1
11	64110348	Plug	1
12	C174 Y	Clevis Pin	1

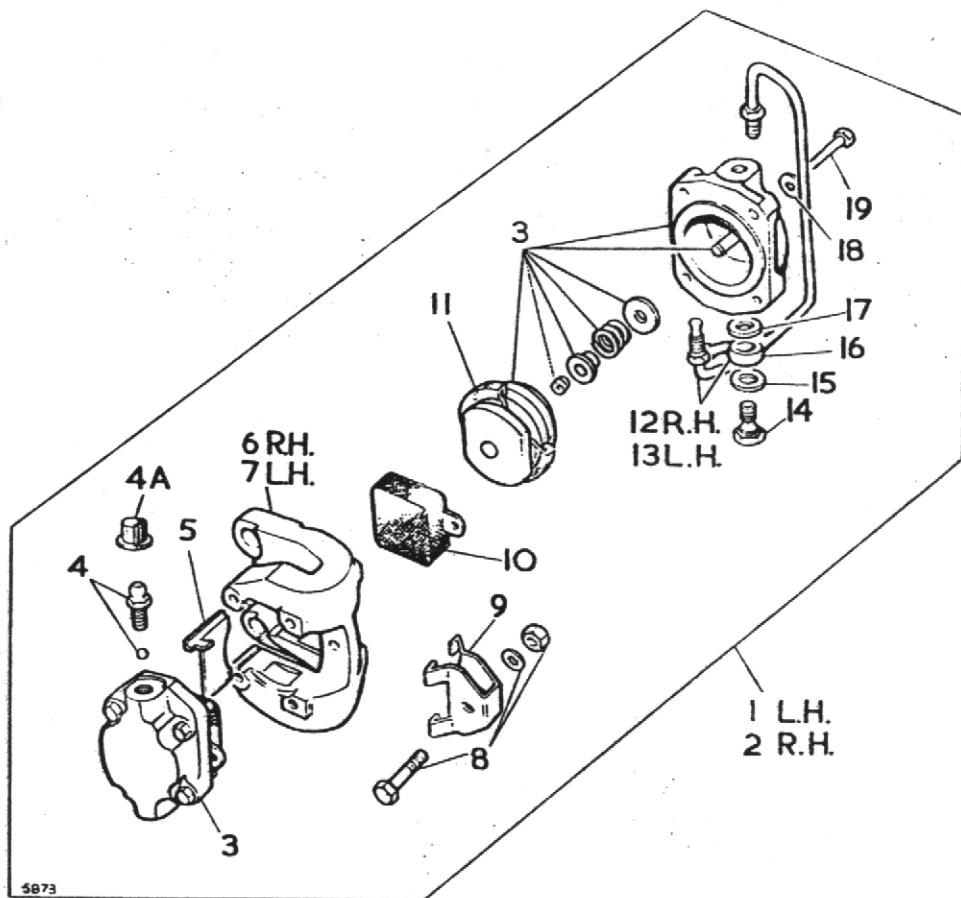

CALIPER ASSEMBLY

Item No.	Part No.	Description	No. Off
1	CB90262	Caliper Assy. Complete (LH)	1
2	CB90263	Caliper Assy. Complete (RH)	1
3	VB05505	Piston & Cylinder Assy.	4
4	VB08378	Bleed Screw & Ball Assy.	2
4A	CB0849	Dust Cover (Bleedscrew)	2
5	VB05133	Plate, Support	4
6	CB60253	Body, Caliper (RH)	1
7	CB60252	Body, Caliper (LH)	1
8	VB08491	Nut, Bolt & Washer (Keep Plate)	2
9	VB05123	Keep Plate	2
10	CB20554Y	Friction Pad Complete (Set of 4)	1 set
11	VB08210A	Seal Kit (Dust & Piston)	4
12	VB03927	Bridge Pipe Assy. (RH)	1
13	VB03926	Bridge Pipe Assy. (LH)	1
14	VB06008	Banjo Bolt $\frac{3}{8}$ " UNF	2
15	VB06113	Washer, Copper	2
16	VB06212	Banjo $\frac{3}{8}$ " UNF	2
17	VB06112	Washer, Copper	2
18	VB06101L	Washer, Shakeproof	16
19	VB05100	Bolt, Retaining (Cylinder)	16

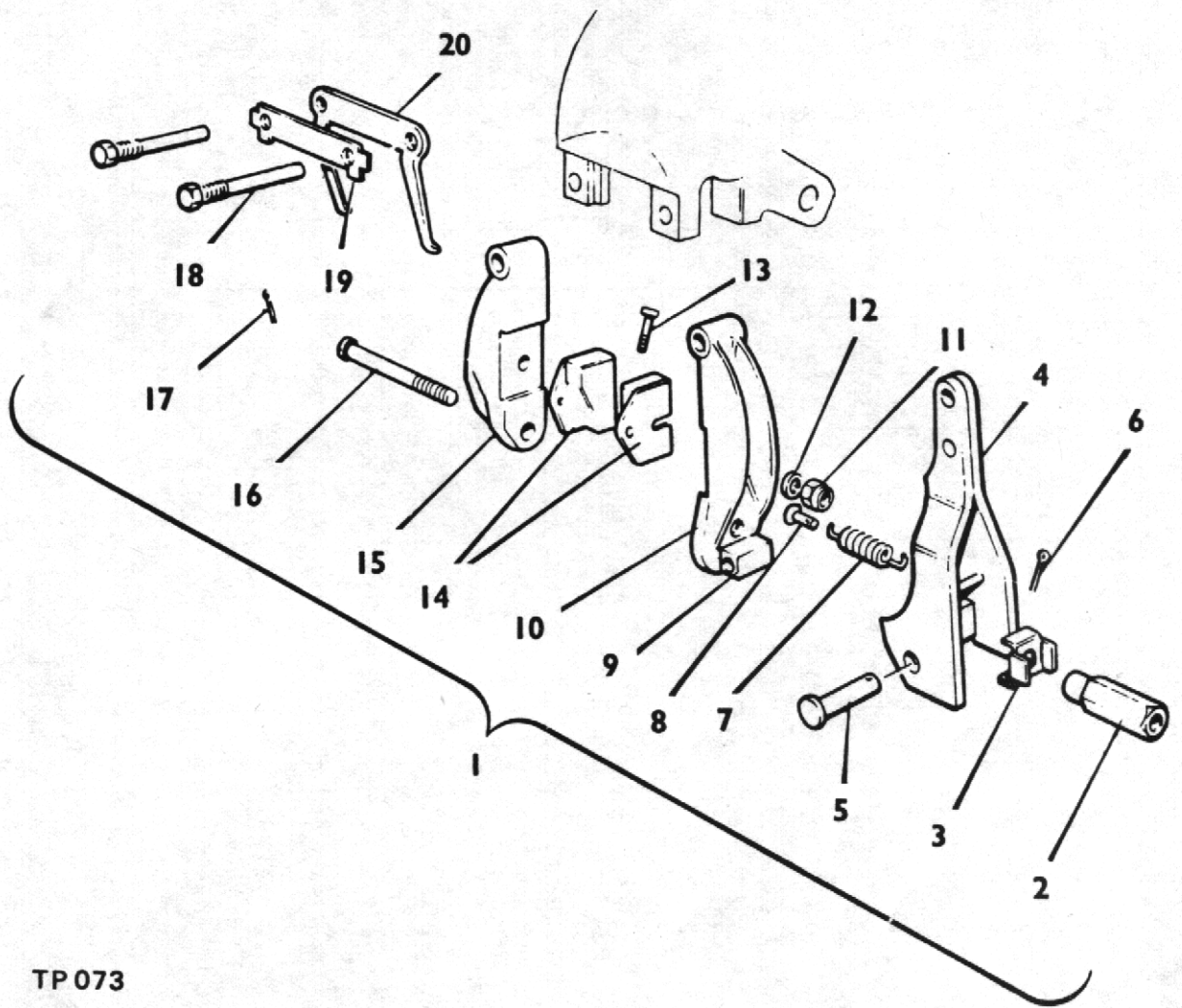

TP 073

HANDBRAKE ASSEMBLY

Item No.	Part No.	Description	Qty
1	CB 90256	Handbrake Assembly complete RH	1
	CB 90257	Handbrake Assembly complete LH	1
2	CB 20258	Adjustment Nut	1
3	VBO 8307	Friction Spring	1
4	CB 20562	Lever Assembly	1
5	VBO 8315	Hinge Pin	1
6	VBO 6135 D	Split Pin	1
7	VBO 7329	Return Spring	1
8	VBO 7330	Spring Anchor	1
9	VBO 8308	Pivot Seat	1
10	CB 60249 8308	Pad Carrier Assembly Inner Complete with Pivot Seat	1
11	VBO 6050	Nut 2 B.A.	2
12	VBO 6101F	Washer	2
13	VBO 4124	Bolt	2
14	CB 20311Y	Friction Pad	2
15	VBM 4573	Pad Carrier Outer	1
16	CB 20289	Bolt	1
17	VBO 6158G	Split Pin	1
18	VBO 4190	Bolt	2
19	VBO 4226	Tab Washer	1
20	VBM 4635/1	Retraction Plate	1

DECIMAL, FRACTIONAL AND METRIC EQUIVALENTS

Inches		Milli- metres	Inches		Milli- metres
Fractions	Decimals		Fractions	Decimals	
1/64	0.015625	0.397	33/64	0.515625	13.097
1/32	0.03125	0.794	17/32	0.53125	13.494
3/64	0.046875	1.191	35/64	0.546875	13.891
1/16	0.0625	1.588	9/16	0.5625	14.288
5/64	0.078125	1.984	37/64	0.578125	14.684
3/32	0.09375	2.381	19/32	0.59375	15.081
7/64	0.109375	2.778	39/64	0.609375	15.478
1/8	0.125	3.175	5/8	0.625	15.875
9/64	0.140625	3.572	41/64	0.640625	16.272
5/32	0.15625	3.969	21/32	0.65625	16.669
11/64	0.171875	4.366	43/64	0.671875	17.066
3/16	0.1875	4.763	11/16	0.6875	17.463
13/64	0.203125	5.159	45/64	0.703125	17.859
7/32	0.21875	5.556	23/32	0.71875	18.256
15/64	0.234375	5.953	47/64	0.734375	18.653
1/4	0.250	6.350	3/4	0.750	19.050
17/64	0.265625	6.747	49/64	0.765625	19.447
9/32	0.28125	7.144	25/32	0.78125	19.844
19/64	0.296875	7.541	51/64	0.796875	20.241
5/16	0.3125	7.938	13/16	0.8125	20.638
21/64	0.328125	8.334	53/64	0.828125	21.034
11/32	0.34375	8.731	27/32	0.84375	21.431
23/64	0.359375	9.128	55/64	0.859375	21.828
3/8	0.375	9.525	7/8	0.875	22.225
25/64	0.390625	9.922	57/64	0.890625	22.622
13/32	0.40625	10.319	29/32	0.90625	23.019
27/64	0.421875	10.716	59/64	0.921875	23.416
7/16	0.4375	11.113	15/16	0.9375	23.813
29/64	0.453125	11.509	61/64	0.953125	24.209
15/32	0.46875	11.906	31/32	0.96875	24.606
31/64	0.484375	12.303	63/64	0.984375	25.003
1/2	0.500	12.700	1	1.000	25.400

INCHES INTO MILLIMETRES

Inches	0	1	2	3	4	5	6	7	8	9
0	0	25.40	50.80	76.20	101.60	127.00	152.40	177.80	203.20	228.60
10	254.00	279.40	304.80	330.20	355.60	381.00	406.40	431.80	457.20	482.60
20	508.00	533.40	558.80	584.20	609.60	635.00	660.40	685.80	711.20	736.60
30	762.00	787.40	812.80	838.20	863.60	889.00	914.40	939.80	965.20	990.60
40	1016.00	1041.40	1066.80	1092.20	1117.60	1143.00	1168.40	1193.80	1219.20	1244.60
50	1270.00	1295.40	1320.80	1346.20	1371.60	1397.00	1422.40	1447.80	1473.20	1498.60
60	1524.00	1549.40	1574.80	1600.20	1625.60	1651.00	1678.40	1701.80	1727.20	1752.60
70	1778.00	1803.40	1828.80	1854.20	1879.60	1905.00	1930.40	1955.80	1981.20	2006.60
80	2032.00	2057.40	2082.80	2108.20	2133.60	2159.00	2184.40	2209.80	2235.20	2260.00
90	2286.00	2311.40	2336.80	2362.20	2387.60	2413.00	2438.40	2463.80	2489.20	2514.61

Use in conjunction with above table.

Example: Find equivalent mm. for 84 5/8".

$$84'' = 2133.60 \text{ mm.}$$

$$5/8'' = 15.875 \text{ mm.}$$

$$84 \text{ } 5/8'' = 2149.475 \text{ mm.}$$

CALIFORNIA

Proposition 65 Warning

Diesel engine exhaust and some of its constituents are known to the State of California to cause cancer, birth defects, and other reproductive harm